



Another  Innovation

WHYNTER SNO PORTABLE AIR CONDITIONER

MODEL# : ARC-13W/S



Thank you for choosing the Whynter SNO portable air conditioner. You have bought one of the best portable air conditioners available today. Follow the instructions given in this booklet to obtain the very best performance from your portable air conditioner and take full advantage of the many advance features that your portable air conditioner offers you. We wish you many years of enjoyable use.

Please keep this user manual in a safe place for future reference.

DISPOSAL



This symbol on the product or its packaging indicates that the appliance cannot be treated as normal domestic trash, but must be handed in at a collection point for recycling electric and electronic appliances. Your contribution to the correct disposal of this product protects the environment. Further information about the recycling of this product can be obtained from your local municipal authority.

PARTS OVERVIEW

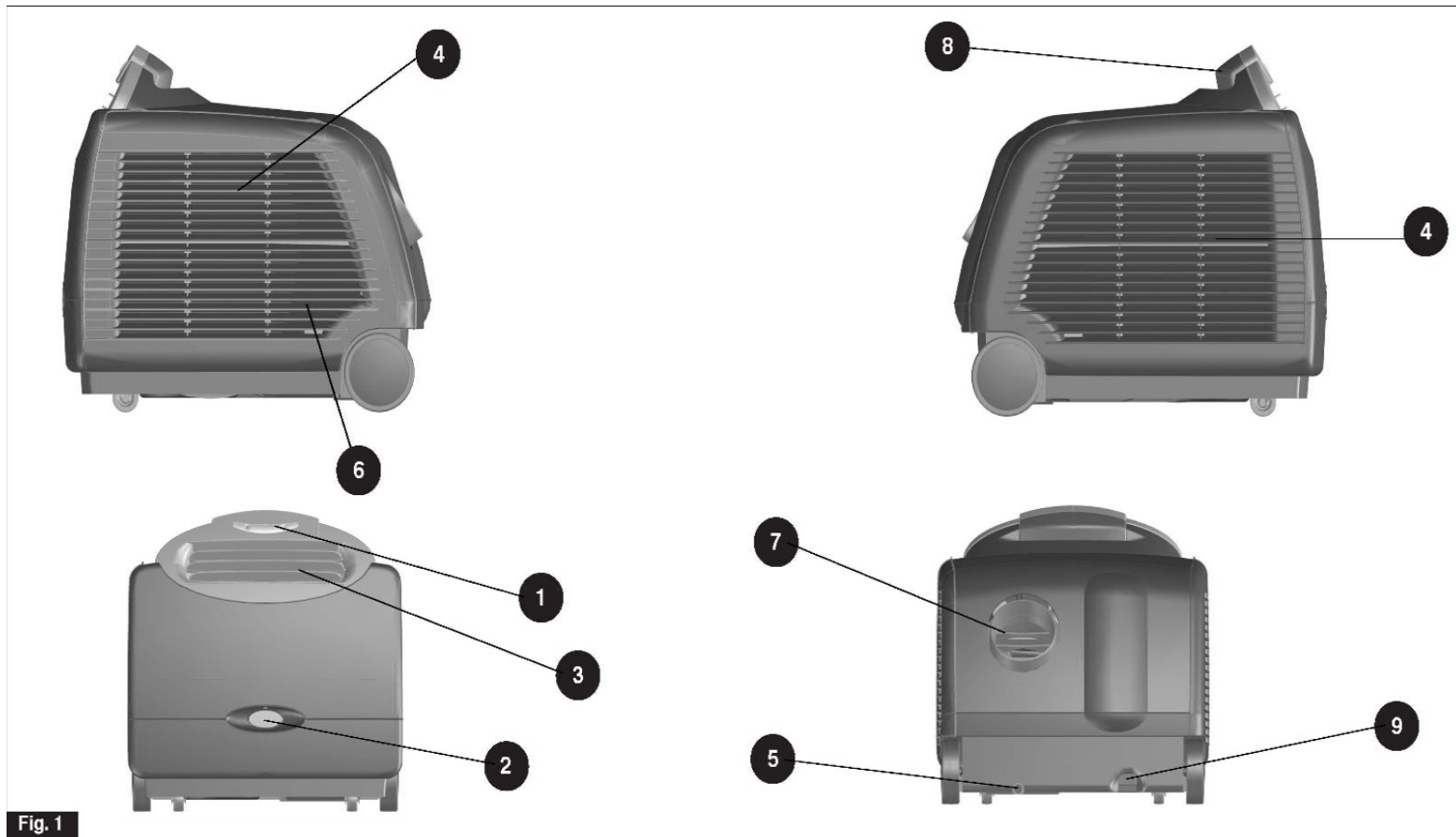

- | | | | | |
|----------------------|--------------------|----------------------|---------------------------|---------------|
| 1. Control panel | 2. Pull handle | 3. Air outlet grille | 4. Air filter with grille | 5. Drain plug |
| 6. Outdoor air inlet | 7. Outdoor exhaust | 8. Top handle | 9. Power cord | |

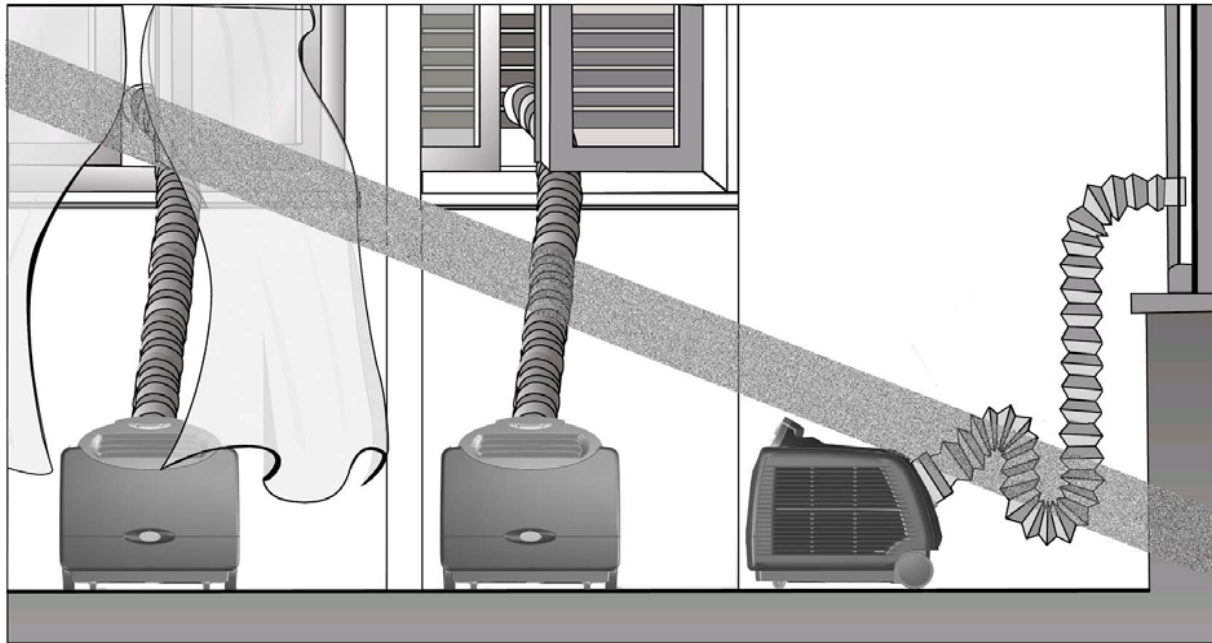

Fig. 2

Incorrect setup

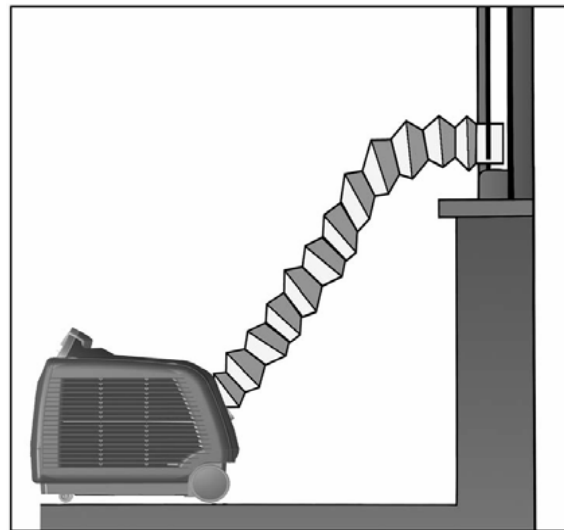

Fig. 3

Correct setup



SAFETY PRECAUTIONS

- Ensure curtains or other objects are not obstructing the air inlet filters. (Fig.2)
- Do not bend or crush the exhaust hose while in use. (Fig.2)
- Transport the unit in an upright position only, or leave it in an upright position for at least 2 hours before first use.
- Always place the unit on even and hard surface.
- The power cord is UL listed. It has a built-in L.C.D.I. (leakage, current, detection, interruption) circuit breaker for added safety. If the power supply is interrupted, press the reset button to reconnect the unit to power source.
- Make sure this unit is connected to a correctly grounded power supply outlet. Do not use an extension cord.
- Do not turn this unit on and off by plugging and unplugging. Always use the ON/OFF switch.
- Do not sit or place objects on the unit.
- Always allow air flow around the portable air conditioner for at least 20'. Do not use this unit inside closets, cabinets and/or cramped spaces between furniture.
- To avoid the risk of shock, the product should never be used in bathrooms, shower rooms, or in any other steamy or wet areas.
- Do not operate this unit without the air filter.
- Do you use harsh chemicals to clean the filter. Dry thoroughly before inserting the filter into the unit
- This unit is optimized to operate in an ambient temperature of 64°F – 100°F.
- Do not repair, disassemble and/or modify the unit by yourself.
- An opening in a window or wall is required to accommodate the exhaust hose (window kit supplied) to exhaust the hot air from the back of the unit.
- Do not add extra length to the exhaust hose by more than a total length of 9'. This will reduce the cooling efficiency of the portable air conditioner.
- Always turn off the portable air conditioner when cleaning the air filter, and transporting.
- At the end of each season, all water must be drained from the unit and filter must be cleaned before storage.
- Do not use an excessively wet cloth, industrial solvents, oil-based products to clean this portable air conditioner.

THE MANUFACTURER DISCLAIMS ANY RESPONSIBILITY IF THE ABOVE INSTRUCTIONS ARE NOT FOLLOWED.

WINDOW KIT INSTALLATION

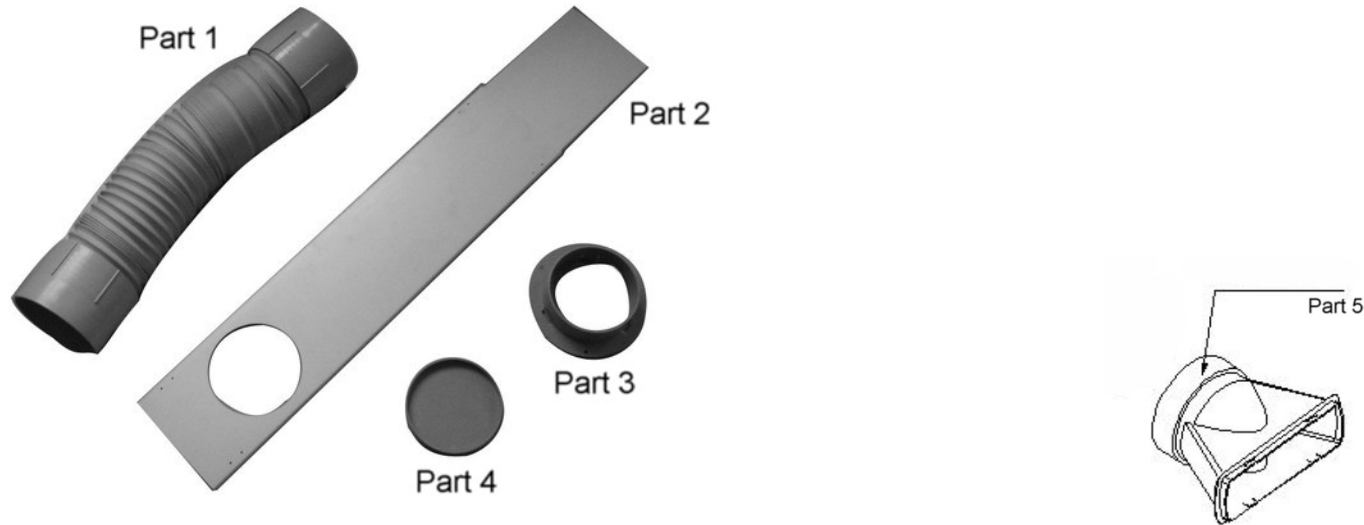

In order for this portable air conditioner to work properly, the hot air from the back of the unit must be vented to the outside. Please follow the instructions below for window kit installation.

1. Extend the exhaust hose (Part 1) at least 6" and insert it to the outdoor exhaust outlet at back of the unit.
2. Attach the round connector (Part 3) to the other end of the hose.
3. Open your window and place the adjustable window slide bar (Part 2) to the opening of the window. Expand the bar so it fits tightly horizontally.
4. Lower the window so the bar fits to the opening of the window tightly.
5. Attach the hose with the round connector to the round opening of the window slide bar.
6. When the air conditioner is not in use, remove the hose from the window slide bar and place the round cover (Part 4) to the opening of the bar.
7. For non-fixed openings, such as doors or sliding doors that may need to be opened or closed, attach the rectangle connector (Part 5) to the end of the hose and place the connector to the opening of the door.

INSTALLATION

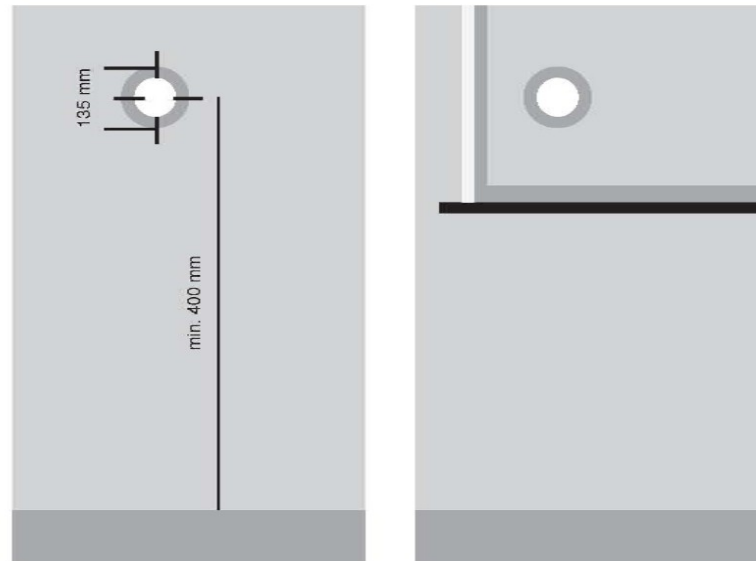
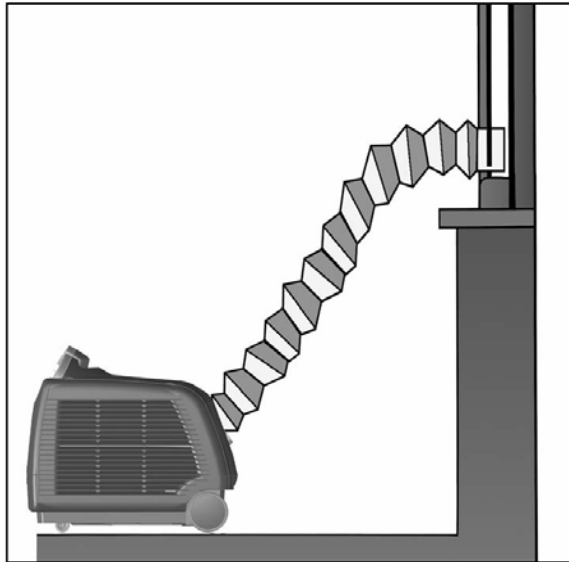

Fig. 4

When you use this air conditioner unit, hot air must be exhausted out of the room to complete the air exchange of the condenser. When the unit is operating in fan-only mode, no exhaust is required.

Exhaust hose Installation

The exhaust hose must be installed onto the unit.

1. Pull out about 6" of one end of the exhaust hose.
2. Screw the exhaust connector on the exhaust hose in a clockwise motion.
3. Snap the exhaust connector in place in the back of the unit.
4. Only extend the exhaust hose to the necessary length.

Window Installation (Fig. 4)

1. Make sure the exhaust hose is properly installed onto the portable air conditioner.
2. Open window or sliding door for approximately 5" (130 mm)
3. Adjust the length of the window kit to the same length and width of the opening of the window or the sliding door. Cut the window piece if necessary to fit the length of your window or sliding door.
4. Place the window kit on your window or sliding door, with the exhaust hole as near to the portable air conditioner as possible.
5. Close the window or sliding door, on the window kit. For long term installation, you may screw the window kit into your window frame.
6. Adjust the length of the exhaust hose and mount the window kit adaptor to the window kit.

NOTE: When using the window kit on a window or sliding door it will cause the window or sliding door not to be properly closed and locked. Additional security measurements maybe needed.

Wall Installation

1. Make sure the exhaust hose is properly installed onto the portable air conditioner.
2. Make a hole of 5.3" (135mm) diameter in the wall.
3. Insert as much as exhaust hose as needed through the hole.

NOTE: Make sure to have a qualified professional to make the hole to avoid the possibility of injury or damage to the structure. Make sure that the hole is covered when it is not used by the portable air conditioner.

CONTROL PANEL

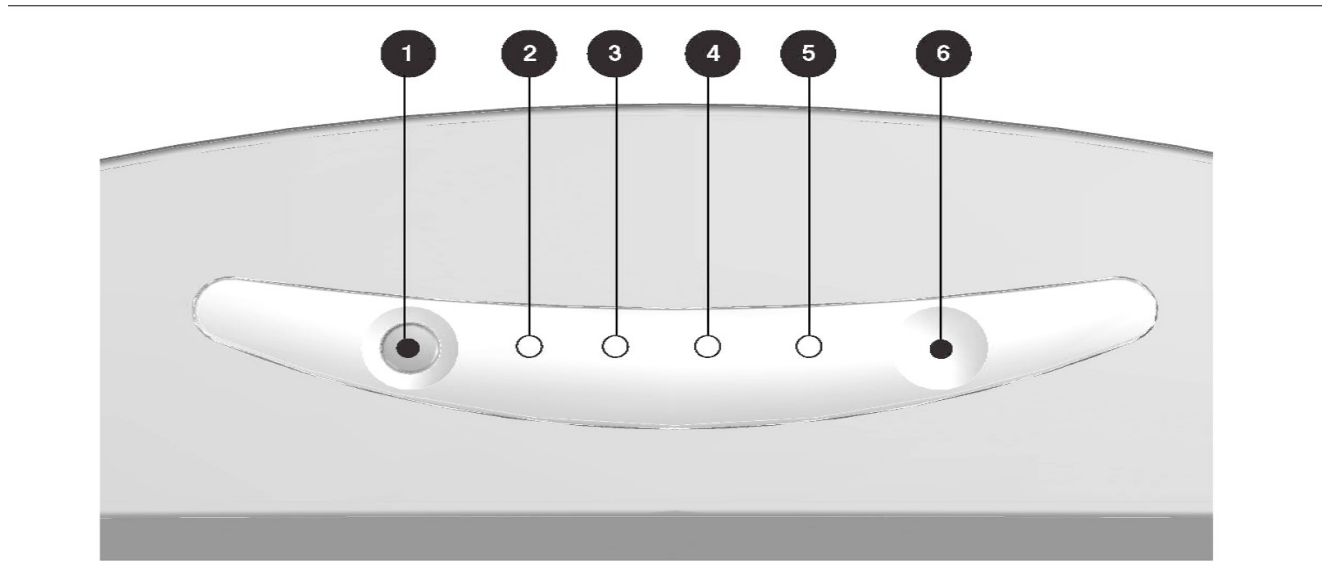

Fig. 5

1. Stand-by or Comfort (automatic) function button
2. Red - Stand-by
3. Green - Air conditioner is on
4. Orange - On and/or off program is enabled
5. Green - Automatic function is on
6. Remote control signal reception button

OPERATIONS

SWITCHING ON THE AIR CONDITIONER

The portable air conditioner can be switched on by the remote control or by pressing the On/Off button on the control panel. Without using the remote control, the unit can only be switched on the Comfort (automatic) function.

To transmit signals from the remote control to the air conditioner, point the front part of the remote handset towards the control panel on the air conditioner. Reception of the signal is confirmed by a beep. The maximum signal transmission distance is approximately 8 meters / 26 feet.

NOTE:

- Other appliances in the same room controlled by a remote control (TV, radio, stereo, etc.), may cause interferences.
- Electronic and fluorescent lamps may interfere with the signal transmissions between the remote control and the air conditioner.
- Remove the batteries if the remote control is not used for long periods.

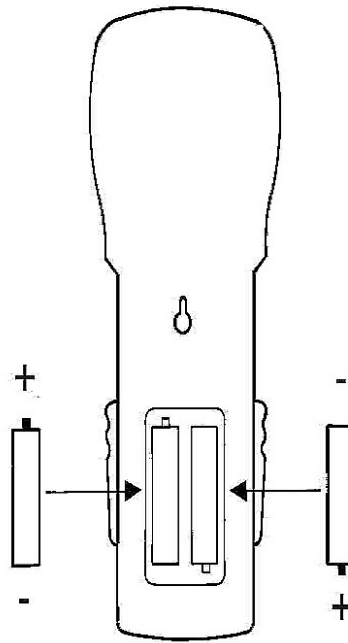
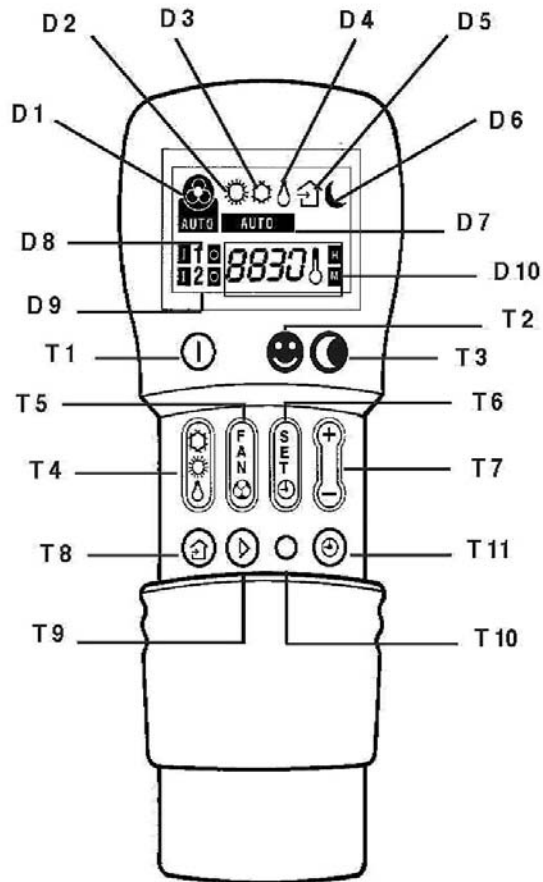

Fig. 6

INSTALLING BATTERIES

- Only use 2 LR03 1.5V Batteries (included) in the remote control.
- Always change both batteries at the same time.
- To insert the batteries, open the flap on the back of the remote control. Strictly adhere to the polarity signs on the bottom of the battery housing, close the flap once the batteries have been inserted (Fig. 6).

REMOTE CONTROL



BUTTONS		DISPLAYS	
T1	On/Off	D1	Fan speed or the automatic fan function mode (AUTO)
T2	Comfort button (automatic)	D2	Heating (not enabled)
T3	Night Comfort button	D3	Cooling function indicator
T4	Function Mode selector	D4	Dehumidifying function indicator
T5	Fan Speed selector	D5	Outdoor air outlet enabled (not enabled)
T6	Set Time and Program button	D6	Night comfort function indicator
T7	Increase (+) / Decrease (-) Temperature / Time value button	D7	Automatic function indicator
T8	Button not enabled	D8	First program indicator
T9	Button not enabled	D9	Second program indicator
T10	Reset button	D10	Temperature (thermometer), hour and minutes (H M) indicator
T11	Enable Program button		

The remote control has a sliding cover. Without pulling the cover down, the remote control can turn On/Off the unit, start or stop the Comfort (automatic) and Night Comfort functions only.

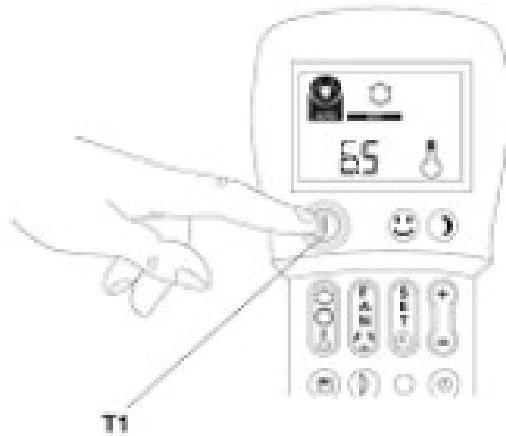

Fig. 8

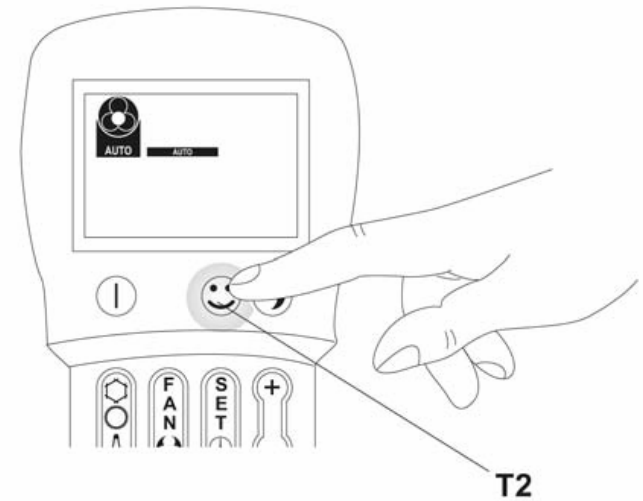

Fig. 9

SWITCHING ON/OFF THE AIR CONDITIONER (Button T1)

Press the T1 button to switch on/off the air conditioner (Fig. 8).

The control system of the air conditioner stores the previously programmed data in its memory; therefore, the settings are not lost when the air conditioner is switched off.

When the red LED (2) on the control panel is illuminated, this indicates that the air conditioner is switched off.

When the green LED (3) on the control panel is illuminated, this indicates that the air conditioner is switched on.

COMFORT (AUTOMATIC) FUNCTION (Button T2)

Press the T2 button (Fig. 9), the air conditioner will automatically run to achieve the optimum comfort temperature of (72°F/ 22°C.)

When the Comfort function is on, the compressor will stop when the temperature is below 72°F and the compressor will start when the temperature is above 72°F.

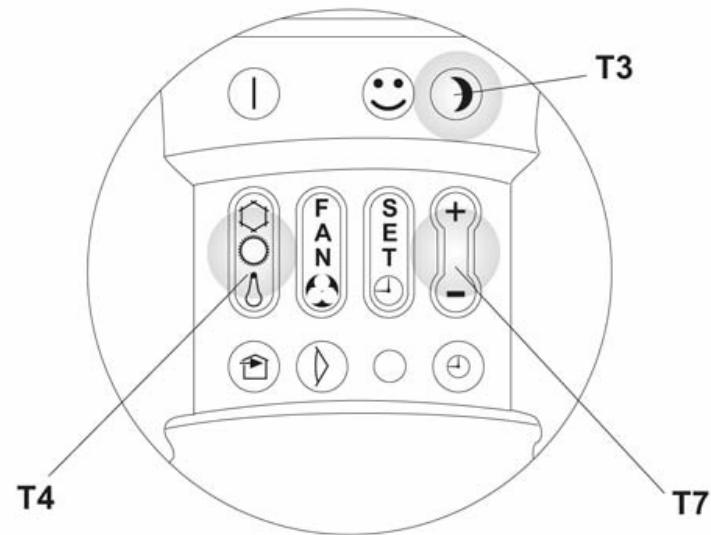

Fig. 14

NIGHT COMFORT BUTTON (Button T3)

Press the T3 button to activate the night comfort function (Fig.14). In this function, the air conditioner gradually increases the set temperature in cooling mode, decreases the noise level and conserves energy at night time. In cooling mode, the set temperature is maintained for an hour after the Night Comfort function has been activated. In the next hour, the temperature is gradually increased by up to 3°F. After the second hour, the temperature remains the same.

To activate the a Night Comfort function, first select the desired function mode by pressing the T4 button, program the desired temperature settling by pressing the T7 (+ / -) button, then press the T3 Night Comfort button. The fan speed of the Night Comfort function is at the lowest and cannot be changed.

The Night Comfort can be cancelled at any moment (ideally when you wake up) by pressing the T3 button. The temperature and fan speed settings (programmed before the Night Comfort function was activated) will be restored.

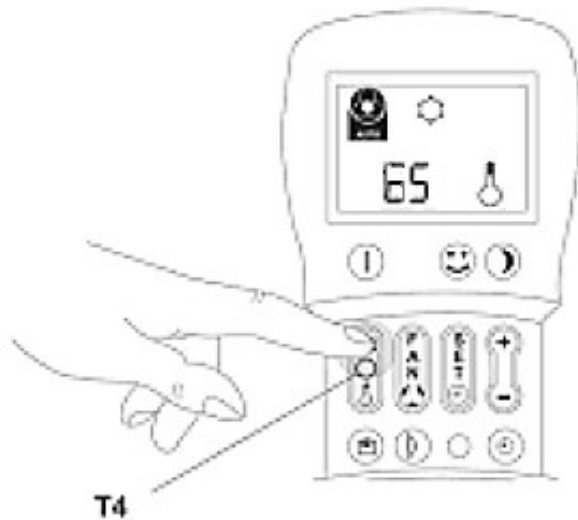

Fig. 10

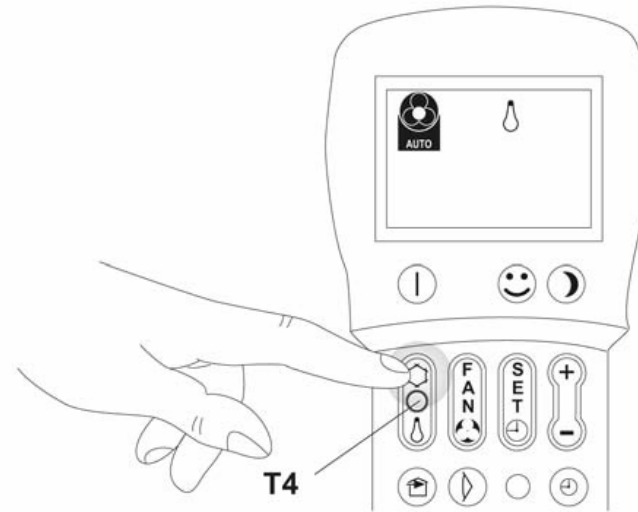

Fig. 11

COOLING/ DEHUMIDIFICATION ONLY/ FAN ONLY FUNCTION (Button T4)

Cooling Mode

In this mode, the air conditioner cools and dehumidifies the room. To activate this function, press the T4 Function Mode Selector button until the FROST symbol appears on the display (Fig. 10). When this function mode is set, the compressor will start in approximately 3 minutes. Subsequently, set the desired temperature and fan speed (refer to the appropriate sections). Please note that when switching function mode, there will be an approximately 3 minutes transition time.

Dehumidifying Only Mode

In this mode, the air conditioner only dehumidifies the room, the compressor will activate intermittently depending on the ambient temperature. To activate this function, press the T4 Function Mode Selector button until the DROPLET symbol appears on the display (Fig. 11). When this function mode is set, the fan speed settings cannot be changed and it is automatically set to minimum. Please note that when switching function mode, there will be an approximately 3 minutes transition time.

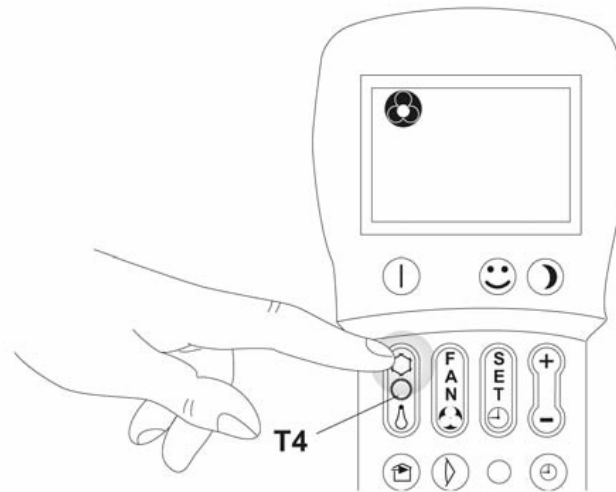

Fig. 12

Fan Only Mode

In this mode, only the fan of the air conditioner runs and circulates the air in the room. To activate this function mode, press the T4 Function Mode Selector button until just the FAN symbol appears on the display (Fig.12). Subsequently, set the desired fan speed. Please note that when switching function mode, there will be an approximately 3 minutes transition time.

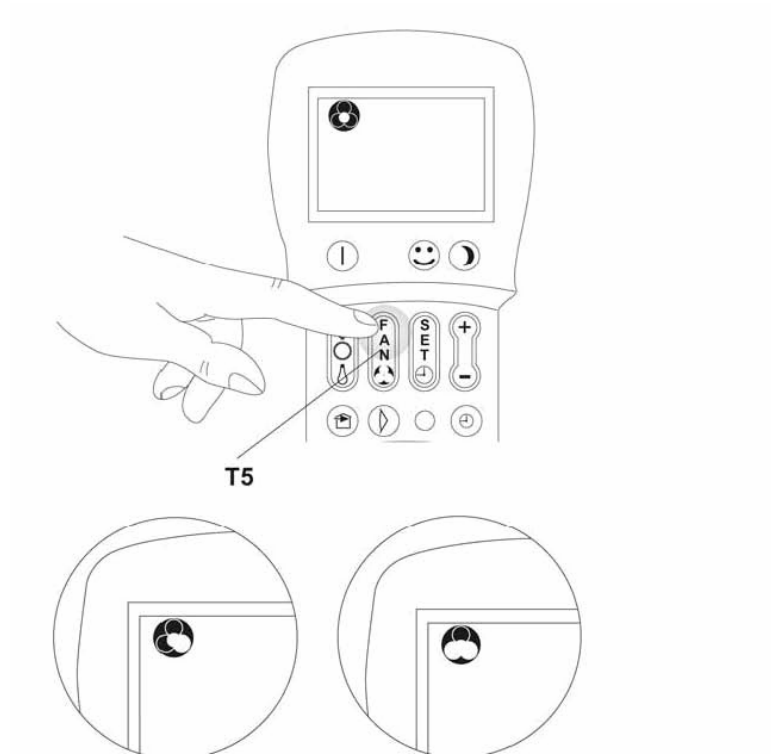

Fig. 13

FAN SPEED CONTROL (Button T5)

Press the T5 button to set the fan speed. To change the fan speed, press this button repeatedly to achieve the following sequence (Fig 13):

- Low, Medium, High and Automatic

When set in Automatic fan speed mode, the air conditioner automatically adjusts the fan speed. In this mode, the greater the difference between the ambient temperature and the set temperature, the higher the fan speed. The fan speed is automatically reduced as the ambient temperature gradually reaches the set temperature.

SETTING THE FUNCTION PROGRAM MODES

This air conditioner has two distinct function programs that can be used to stop and start the appliance at certain times (for example the air conditioner can be programmed to start just before you get home so when you arrive home, the temperature is pleasant). If you wish to use these functions, it is necessary to set the exact time and the function programs to run at the desired times.

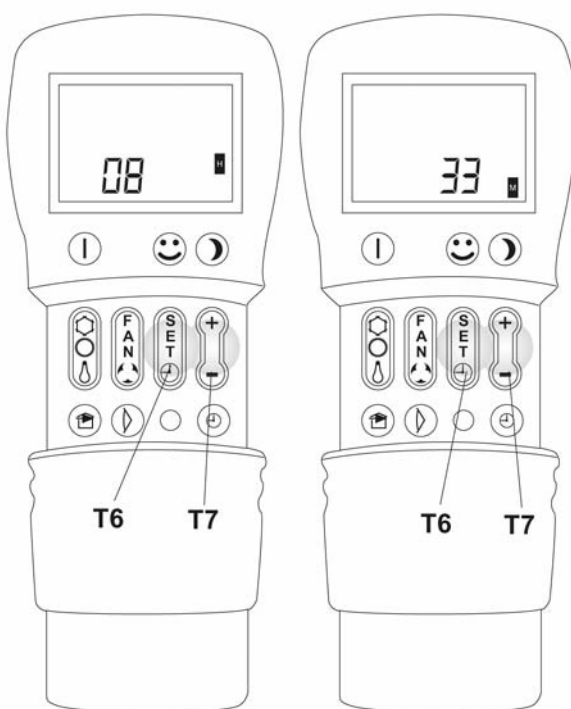

Fig. 15

SETTING THE CURRENT TIME ON THE REMOTE CONTROL (Button T6-T7)

To set the exact time, proceed as follows (Fig.15):

- Press the T6 Set time and Program button repeatedly until the hour (H) symbol appears on the display.
- Press the T7 +/- button to increase or decrease the hour (0-23) until the exact hour value is displayed.
- Press the T6 Set time and Program button again until the minute (M) symbol appears on the display.
- Press the T7 +/- button to increase or decrease the minute (0-59) until the exact minute value is displayed.

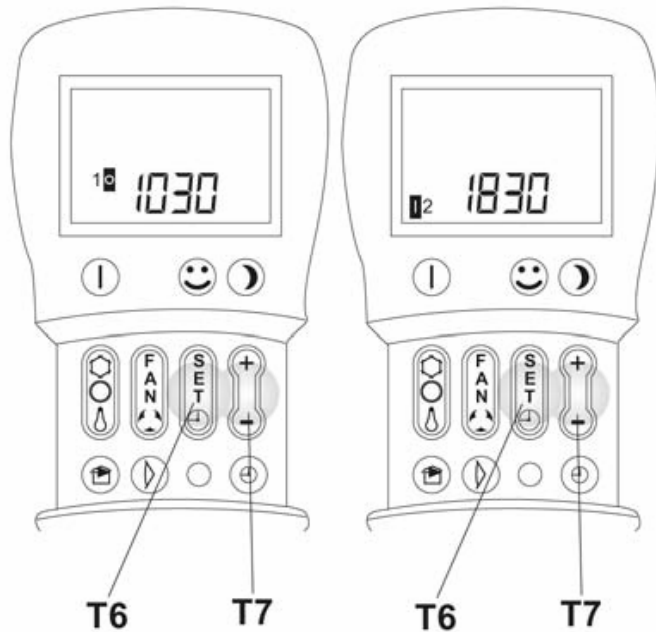

Fig. 16

Setting the On/Off times of the 1st and 2nd Function Programs (PROGR. 1 and PROGR.2)

To set the air conditioner On/Off times for the two programs proceed as follows (Fig. 16):

- To set the start time of the 1st program
 - Press the T6 Set Time and Program button repeatedly until the PROGR.1 (D8) symbol with a vertical line on the left appears on the display (the start time of the 1st program) is displayed.
 - Press the T7 +/- button to set the time (0:00 – 23:30) when you want the 1st program to start. The timer interval is 30 minutes.
- To set the stop time of the 1st program
 - Press the T6 Set Time and Program button again. PROGR.1 (D8) symbol with a circle on the right (the stop time of the 1st program) will appear on the display.
 - Press the T7 +/- button to set the time (0:00 – 23:30) when you want the 1st program to stop. The timer interval is 30 minutes.

- To set the start time of the 2nd program
 - Press the T6 Set Time and Program button repeatedly until the PROGR.2 (D9) symbol with a vertical line on the left appears on the display (the start time of the 1st program) is displayed.
 - Press the T7 +/- button to set the time (0:00 – 23:30) when you want the 2nd program to start. The timer interval is 30 minutes.
 - To set the stop time of the 2nd program
 - Press the T6 Set Time and Program button again. PROGR.2 (D9) symbol with a circle on the right (the stop time of the 1st program) will appear on the display.
 - Press the T7 +/- button to set the time (0:00 – 23:30) when you want the 2nd program to stop. The timer interval is 30 minutes.
- To active one or both function programs, press the T11 Enable Program button. To return to normal function mode, press the T6 button repeatedly until the program symbols disappear from the display.

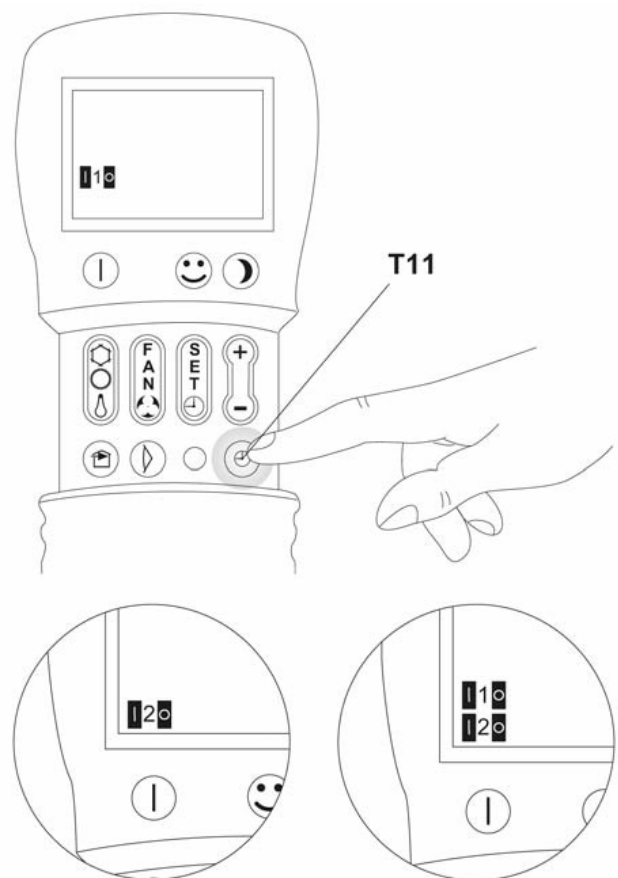

Fig. 17

ENABLING AND DISABLING THE FUNCTION PROGRAMS (Button T11)

The function program(s) (either one or both) can be enabled or disabled (Fig. 17).

- Press the T11 Enable Program button once and the 1st program (D8) is enabled. Press the T11 button again, the 2nd program (D9) is enabled.
- Press the T11 button again, the 1st and 2nd programs (D8 & D9) are enabled.
- Press the T11 button again, both programs are disabled.

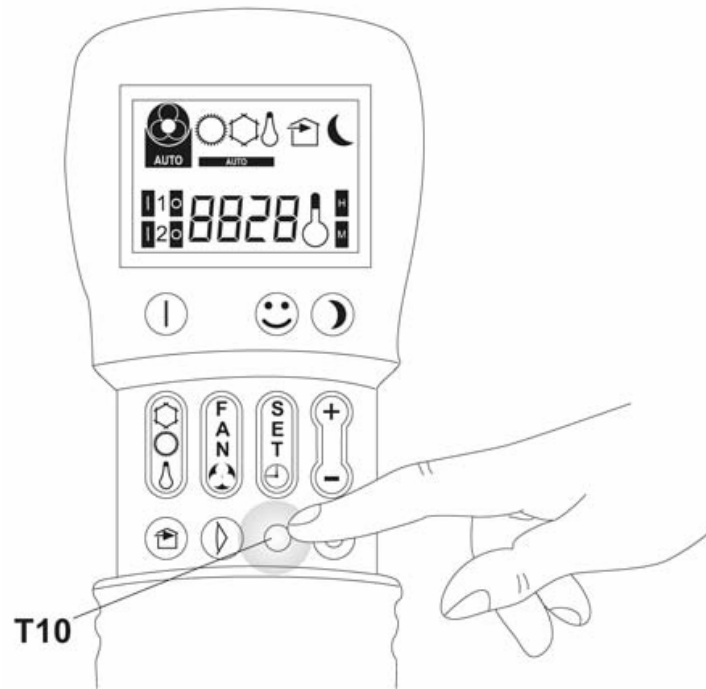

Fig. 18

RESETTING ALL REMOTE CONTROL FUNCTIONS (Button T10)

Press the T10 button to reset all remote control settings including timer and temperature settings (Fig. 18).

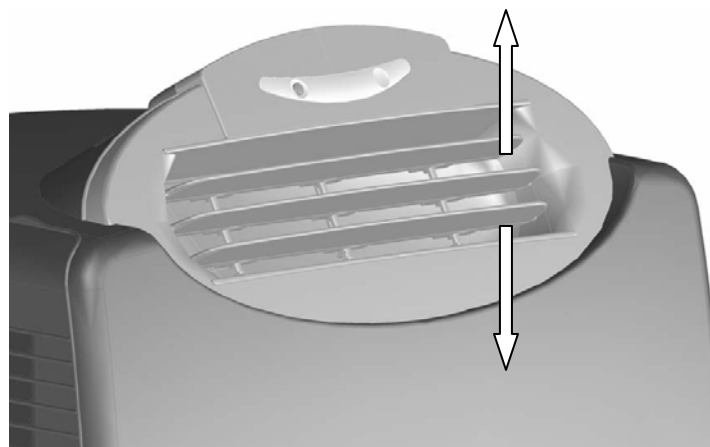

Fig. 19

CONTROLLING THE AIR FLOW DIRECTION

The direction of the airflow can be controlled vertically by moving the louvers up or down (Fig. 19).

HOW TO MANAGE THE AIR CONDITIONER WITHOUT THE REMOTE CONTROL

If it is not possible to use the remote control either because it was lost, has malfunctioned or the batteries are flat, the air conditioner can only be used in Comfort (automatic) mode by pressing the stand-by button (1) on the control panel for 5 seconds. When all of the LEDs on the control panel start to flash, this indicates that Comfort function has been enabled. To restore the normal remote control function, press any button on the remote control.

TRANSPORTATION



Fig. 20

The air conditioner is equipped with wheels and handles for easy portability.

Before moving the air conditioner, proceed as follows:

- Switch off the air conditioner and disconnect the plug from the power outlet
- Drain water by removing the drain plug.
- Always transport the air conditioner in an upright position only.

For short distances, use the top handle (Part 8). For greater distances, use the pull handle (Part 2) on the front of the air conditioner.

- Pull the handle belt from the housing (Fig. 20).
- Move the air conditioner as desired.
- Reposition the pull handle back into its housing.

MAINTENANCE



Fig. 22

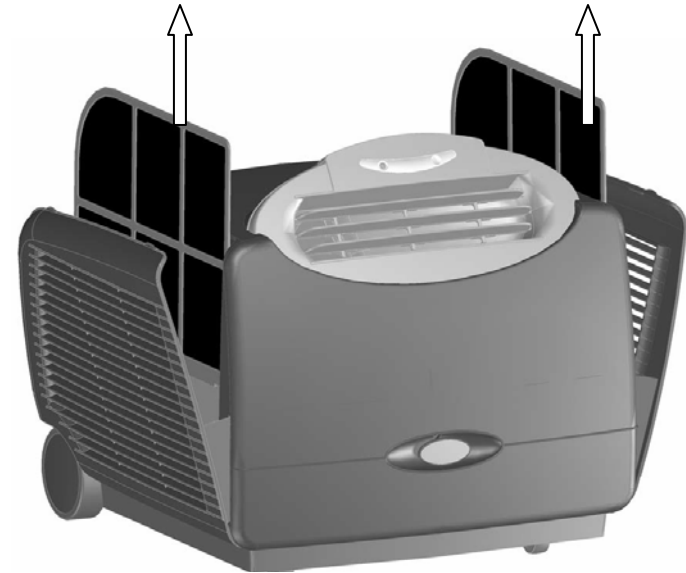

Fig. 23

CLEANING THE AIR FILTER

To ensure the air intake is filtered properly and to assure that your air conditioner runs efficiently, it is crucial to clean the air filters regularly.

When the air conditioner has been in use for a certain amount of time, the green LED (3) on the control panel (Fig. 5) will start to flash indicating that it is time to clean the air filters.

- Press the stand-by button to switch off the air conditioner. Remove the air filters housed in the air intake grilles on each side.
- Press the grips to release the air grilles and pull the filters frames up to remove from the frame (Fig. 22 & 23).
- Use a vacuum cleaner or tap lightly to remove loose dust and dirt from the filters. Then rinse them thoroughly under warm or cold running water (no hotter than 100F.)
- Dry thoroughly before re-inserting the filters.



WARNING! Never operate the air conditioner without the filters in place.

CLEANING THE AIR CONDITIONER

- Always switch off the air conditioner and disconnect the plug from the power supply outlet before cleaning the air conditioner.
- Use a soft damp cloth to wipe the body of the air conditioner.
- Never use harsh chemicals, oil-based products, detergents, chemically treated cloths or other cleaning solutions. These could possibly damage the body of the air conditioner.

END OF SEASON STORAGE

- Switch off the air conditioner and disconnect the plug from the power supply outlet before cleaning the air conditioner.
- Clean the air filters
- Drain the condensed water COMPLETELY
- On a warm day, turn on the Fan only mode for a couple of hours so that the inside can dry out completely.
- It is recommended that the air conditioner be put back into its original carton for storage.
- Do not stack heavy objects on top of the air conditioner.
- Make sure to store the remote control with the air conditioner.

TROUBLESHOOTING

Problem	Possible Causes	Solutions
The portable air conditioner does not turn on	<p>There was a power failure</p> <p>The automatic switch, line fuse, or breaker has been tripped</p> <p>The power supply voltage is too low</p> <p>The power cord is damaged</p> <p>The LCDI plug for the unit is tripped</p>	<p>Restore the power supply</p> <p>Flip the switch / change the fuse / turn the breaker back on. Also note that you may have too many appliances drawing power on one circuit, so you may need to move the other appliances to another circuit</p> <p>Move the unit onto another circuit with the correct voltage</p> <p>Call for service. Only authorized personnel should replace damaged power cord or power plug</p> <p>Press the Reset button on the LCDI plug</p>
The unit turns on, but the compressor does not turn on (the fan runs but the unit is not cooling)	<p>The room temperature is outside of the operational tolerances of the unit</p> <p>The Cooling mode is not on</p> <p>The compressor has not turned on yet because of its time delay</p> <p>The set temperature is too high</p> <p>The internal water reservoir is full</p>	<p>This unit is designed to work in ambient temperatures of 64°F to 100°F</p> <p>Press the Function Mode (T4) button until the Cooling icon (D3) is shown on the remote control. Make sure that the reception of the signal is confirmed by a beep.</p> <p>Give the compressor 3 minutes to turn on after the Cooling mode has been selected</p> <p>Set the air conditioner to a lower temperature</p> <p>Either manually drain the water or allow the unit to exhaust the water itself. Then cooling will resume</p>
The air coming out of the unit is not very cold, or the airflow volume is weak	<p>The filters are dirty or obstructed</p> <p>The air intake is obstructed</p>	<p>Clean the filters</p> <p>Make sure there is at least 20" of clearance from the air intake</p> <p>Make the length of the exhaust hose is as short as possible</p>

	<p>The exhaust is obstructed</p> <p>The unit is set in dehumidifying or fan mode</p> <p>The unit is set to low fan speed</p>	<p>Check for and remove any obstructions</p> <p>Set the unit in cooling mode</p> <p>Set the unit to a higher fan speed</p>
<p>The unit has worked for a long time, but the room is not cold enough</p>	<p>Windows or doors are open</p> <p>There are too many people in the room</p> <p>There is direct sunshine into the room</p> <p>The room is a kitchen, with many heat-producing appliances</p> <p>There is a server in the room</p> <p>The room is too large</p> <p>There are many electrical appliances in the room</p>	<p>Close all windows and doors into the room when the unit is cooling</p> <p>You may need additional cooling or another air conditioner</p> <p>Close curtains and blinds and try to minimize the amount of direct sunlight into the room</p> <p>You may need additional cooling or another air conditioner</p> <p>You may need additional cooling or another air conditioner</p> <p>You may need additional cooling or another air conditioner</p> <p>You may need additional cooling or another air conditioner</p>
<p>The unit is very noisy</p>	<p>The unit is not level</p> <p>The surface underneath the unit is uneven</p>	<p>Make sure the unit is level</p> <p>Move the unit to a location with a level and hard floor</p>
<p>The unit is leaking water onto the floor</p>	<p>The unit is tilted, or is not level</p> <p>The water tank is full</p>	<p>Make use the unit is level</p> <p>Drain water from the drain plug at the back of the air conditioner</p>

TECHNICAL DATA

Cooling capacity	13,000 BTU
Recommended room size*	450 – 500 sq. ft.
E.E.R. – Energy efficiency rate	11.06
Power supply	115v/ 60Hz
Maximum power input	1175 W
Maximum input	10.21 Amp
Dehumidifying capacity	43 Pts / Day
Function programs	2
Thermostat	64F - 86F
Refrigerant	R-22
Compressor	Rotary
Air flow (max)	380 m3/ Hour
Fan speeds	3 (H, M, L)
Exhaust hose length	5 ft.
Unit Dimensions	20.5" L x 19" H x 21.7" D
Unit Weight	79 lbs
Noise level (acoustic power)	Min. 34 – max. 43

* Uninsulated rooms such as sunrooms, garages, or attics should be less than 450 sq. ft.

ONE YEAR LIMITED WARRANTY & FIVE YEAR WARRANTY ON COMPRESSOR

This WHYNTER SNO portable air conditioner is warranted, to the original owner within the 48 continental states, for one year from the date of purchase against defects in material and workmanship under normal use and service. Should your SNO portable air conditioner prove defective within one year from the date of purchase, return the defective part or unit, freight prepaid (within two months of purchase; after two months to one year, customer will be responsible for freight cost to Whynter's service department), along with an explanation to Whynter's service department. Please ship the SNO portable air conditioner in its original packaging material to avoid damage in transit. Please retain original box and packaging material. Under this warranty, Whynter will repair or replace any parts found defective. This warranty is not transferable. After the expiration of the warranty, the cost of labor and parts will be the responsibility of the original owner of the unit.

THIS WARRANTY DOES NOT COVER:

- Acts of God, such as fire, flood, hurricanes, earthquakes and tornadoes.
- Damage, accidental or other wise, to the portable air conditioner while in the possession of a consumer not caused by a defect in material or workmanship;
- Damage caused by consumer misuse, tampering, or failure to follow the care and special handling provisions in the instructions.
- Damage to the finish of the housing, case, or other appearance parts caused by wear.
 - 1) Filter.
 - 2) Damage caused by repairs or alterations of the unit by anyone other than authorized by the manufacturer.
 - 3) Freight and Insurance cost for the warranty service.

To obtain service or information, contact
Whynter Innovations Group via Email at service@whynter.com or call 866-WHYNTER.