



# TBR-185SR

## OWNER'S MANUAL

---



## Whynter Portable 1.8 cu.ft. Tool Box Refrigerator with 2 Drawers and Lock

**Congratulations on your new Whynter product!**

To ensure proper operation, please read this Instruction Manual carefully before using this product. Keep this manual in a safe place for future reference.



# Table of Contents

<b>Table of Contents</b> .....	<b>2</b>
<b>Safety Precautions</b> .....	<b>2-3</b>
<b>Parts and Accessories</b> .....	<b>4</b>
<b>Technical Data</b> .....	<b>5</b>
<b>Installation</b> .....	<b>5</b>
<b>Operation and Controls</b> .....	<b>7</b>
<b>Cleaning and Maintenance</b> .....	<b>8</b>
<b>Troubleshooting</b> .....	<b>9</b>
<b>Warranty</b> .....	<b>10</b>

## SAFETY PRECAUTIONS



### To Reduce The Risk Of Fire, Electrical Shock, Or Injury When Using Your Tool Box Refrigerator, Follow These Basic Precautions.

- This appliance is not intended for use by persons (including children with reduced physical, sensory or mental capabilities, or lack of experience and knowledge, unless they have been given supervision or instruction concerning use of the appliance by a person responsible for their safety.
- Children should be supervised to ensure that they do not play with the appliance.
- If the power cord is damaged, it must be replaced by the manufacturer or its service agent or a similarly qualified person in order to avoid a hazard.
- Read all instructions before using the appliance.
- Never clean appliance parts with flammable fluids. The fumes can create a fire hazard. Do not use an excessively wet cloth, industrial solvents, and oil-based products to clean this appliance.
- To clean the Tool Box Refrigerator, use only mild detergents. Never use harsh chemicals or solvents.
- Do not store or use gasoline or any other flammable vapors and liquids in the vicinity of this or any other appliance. The fumes can create a fire hazard.
- Do not abuse, sit on, or stand on the appliance.
- Ensure the Tool Box Refrigerator is unplugged before cleaning or if not in use.
- Use the Tool Box Refrigerator only for its intended function. This appliance is designed for household, non-commercial use only. Any other use will void the warranty.
- Do not plug this Tool Box Refrigerator into the power source before setup is completed.
- An empty Tool Box Refrigerator can be dangerous for children and small animals. If disposing of the Tool Box Refrigerator, remove gaskets, latches, and the entire refrigerator door from your unused appliance so that children or small animals cannot be trapped inside.
- The Tool Box Refrigerator is an electrical appliance. To avoid serious injury from electrical shock, do not operate the Tool Box Refrigerator with wet hands, while standing on a wet surface, or while standing in water.
- To avoid the risk of shock, the product should never be used in bathrooms, shower rooms, or in any other steamy or wet areas.
- During installation, the power supply must not be excessively or dangerously bent or flattened.
- Do not tamper with controls.
- Make sure the power cord is placed fully and firm into the power source. If the wall receptacle you intend to use is not adequately grounded or protected by a time delay fuse or circuit breaker, have a qualified electrician install an outlet that is appropriate to local electrical codes and requirements.
- Do not use multiple outlets or an extension cord as it may overheat and become a risk of fire. Please ensure that the Tool Box Refrigerator is plugged directly into the electrical outlet.
- The cord should be secured behind the unit and should not be left exposed or dangling.
- Make sure the power cord is clean before use.
- Make sure hands are dry when connecting the power cord. The appliance is equipped with a three-prong grounded plug on the power cord for your protection. Never modify, remove or attempt to repair the power cord yourself.
- Never pull the power cord to disconnect the unit from an outlet. Grasp the plug directly and pull it from the outlet.
- Never lift or carry the Tool Box Refrigerator by the power cord.
- Keep the power cord away from heated surfaces.
- Do not repair, disassemble or modify the appliance by yourself.
- Always turn off the appliance when cleaning or transporting.

## SAFETY PRECAUTIONS

### WARNING:

- Transport the appliance in an upright position only.
- Place the appliance on a hard, even, and level surface that is strong enough to support it when it is fully loaded
- Close the tool box refrigerator door immediately after putting in any items to maintain the internal temperature of the unit.
- Avoid placing the tool box refrigerator near external heat sources or direct sunlight.
- Place your appliance on a hard and level floor that is strong enough to support it when it is fully loaded.
- Do not turn the tool box refrigerator upside down, on its side, or 45° or more off level.
- Keep fingers out of the “pinch point” areas; clearances between the door and compartment are necessarily small. Be careful closing drawers and door when children are in the area.
- Do not touch the cold surfaces in the tool box refrigerator compartment when hands are damp or wet, skin may stick to these extremely cold surfaces.
- Do not move this tool box refrigerator without securing the door in a closed and latched position.
- Do not drill holes or install other objects on the casing.
- This tool box refrigerator is not suitable for storage of pharmaceutical products.
- Performance may vary based on operational and ambient conditions.

### DANGER:

- Risk Of Fire or Explosion. Flammable Refrigerant Used. Do Not Use Mechanical Devices To Defrost Refrigerator. Do Not Puncture Refrigerant Tubing.
- Risk Of Fire Or Explosion. Flammable Refrigerant Used. Consult Repair Manual/Owner's Guide Before Attempting To Install or Service This Product. All Safety Precautions Must be Followed.
- Risk Of Fire Or Explosion. Dispose Of Properly In Accordance With Federal Or Local Regulations. Flammable Refrigerant

Used.

- Risk Of Fire Or Explosion. Flammable Refrigerant Used. To Be Repaired Only By Trained Service Personnel. Do Not Puncture Refrigerant Tubing.
- Risk Of Fire Or Explosion Due To Puncture Of Refrigerant Tubing; Follow Handling Instructions Carefully. Flammable Refrigerant Used.

### ELECTRICAL CONNECTION

The power cord of this appliance is equipped with a 3-prong (grounding) plug which mates with a standard 3-prong (grounding) wall outlet to minimize the possibility of electric shock hazard from this appliance. Have the wall outlet and circuit checked by a qualified electrician to make sure the outlet is properly grounded. Where a standard 2-prong wall outlet is encountered, it is your personal responsibility and obligation to have it replaced with a properly grounded 3-prong wall outlet. Do not use an adapter. The refrigerator should always be plugged into its own individual electrical outlet which has a voltage rating that matches the rating plate. A 115 Volt AC, 60 Hz, 15- or 20-amp fused, grounded electrical supply is required. This provides the best performance and also prevents overloading house wiring circuits which could cause a fire hazard from overheated wires. Never unplug your refrigerator by pulling on the power cord. Always grip plug firmly and pull straight out from the outlet. Repair or replace immediately all power cords that have become frayed or otherwise damaged. Do not use a cord that shows cracks or abrasion damage along its length or at either end. When moving the refrigerator away from the wall, be careful not to roll over or damage the power cord. Avoid using extension cords to prevent compressor failure.



### Caution: Risk of fire / Flammable materials

- The main plug of the unit must feature an earthing contact. Do not introduce plug into a socket without effective earthing (if in doubt, please consult a certified technician).
- Do not remove any protective features.
- Never work on the refrigerator with a hose or high pressure cleaner. All maintenance work must be carried out by a certified technician.
- Disassembly must be carried out by certified technician. Keep the ventilation holes in the cabinet free from obstructions.
- Do not use any mechanical or other tool different from the ones recommended by the manufacturer, in order to speed up the defrosting.
- WARNING: Keep clear of obstruction all ventilation openings in the appliance enclosure.
- WARNING: Do not use mechanical devices or other means to accelerate the defrosting process, other than those recommended by the manufacturer.
- WARNING: Do not damage the circuit of the refrigerant circuit.
- WARNING: Do not store explosive substances such as aerosol cans with a flammable propellant in this appliance.
- WARNING: Do not use electrical appliances inside the food storage compartments of the appliance, unless they are of the type recommended by the manufacturer.
- Do not use any electrical appliance, apart from the ones recommended by the manufacturer, inside the freezing compartment.
- Keep enough space in order to easily reach the main plug. If the power cable is damaged, it must be replaced by the manufacturer or by its after sales service, or in any case by a person with similar title, to prevent any possible risk.
- Do not damage the refrigerant circuit.
- Do not puncture refrigerant tubing.

### SAVE THESE INSTRUCTIONS

For continued safe use of your appliance.

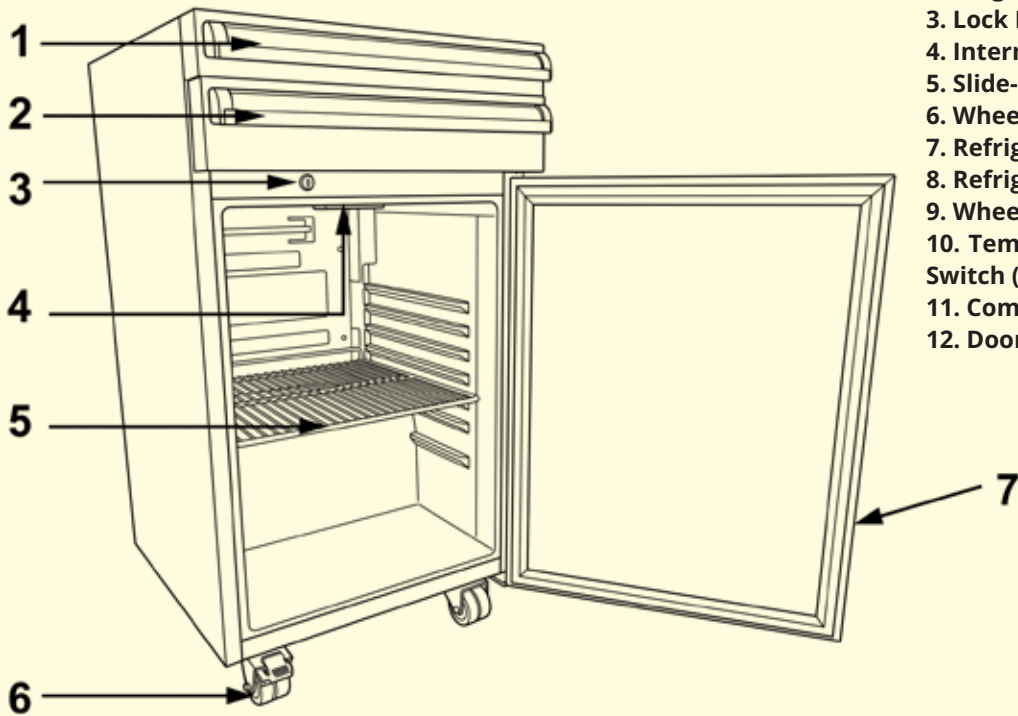

- 1. Small Drawer
- 2. Large Drawer
- 3. Lock Key Hole
- 4. Internal Light
- 5. Slide-Out Refrigerator Wire Shelf (1)
- 6. Wheel casters with lock (2)
- 7. Refrigerator Door
- 8. Refrigerator Handle Bars (4)
- 9. Wheel casters (2)
- 10. Temperature Control Knob | Light Switch (Rear)
- 11. Compressor (Rear)
- 12. Door Keys

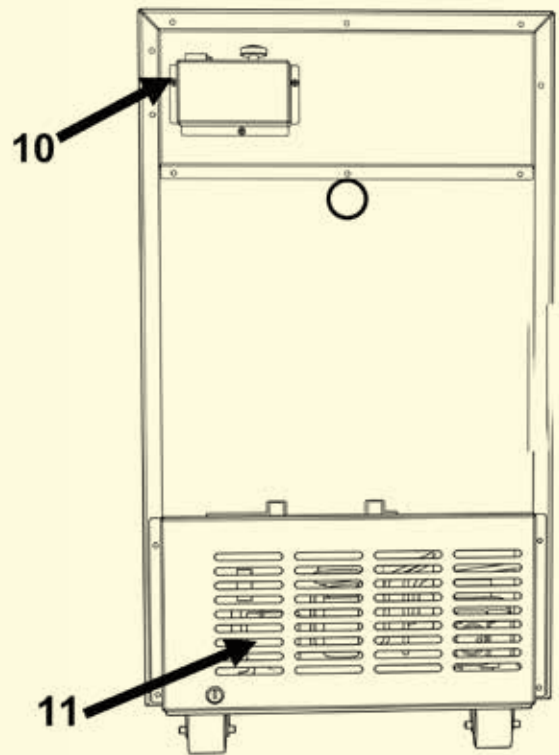
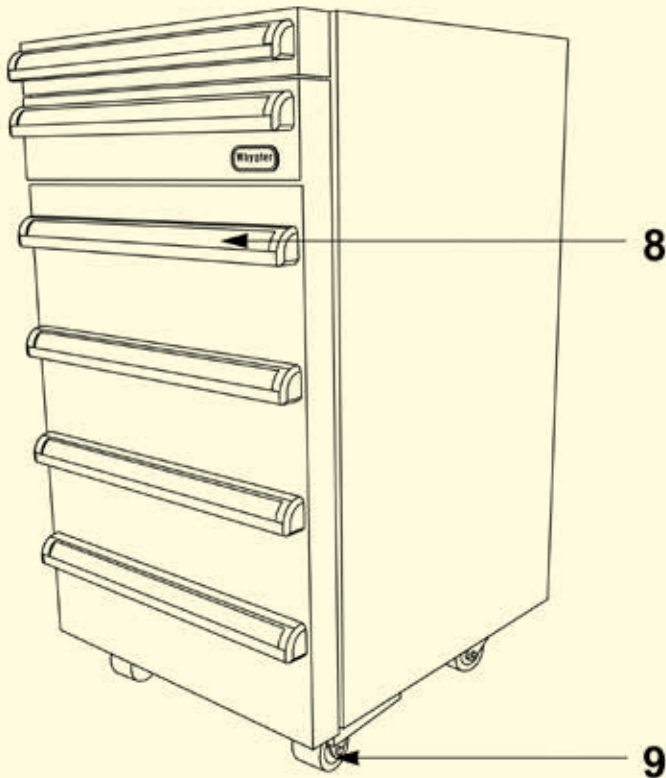

## TECHNICAL DATA

Designed to work as hard as you do, the Whynter Portable 1.8 cu. ft. Tool Box Refrigerator blends cold storage with a rugged, functional tool box design. It is a natural fit for kitchens, offices, garages, and workshops where convenience and durability matter. The tool box styling helps it blend seamlessly into workspaces while keeping drinks and essentials within easy reach. Built for everyday reliability, this refrigerator features a red powder-coated steel construction body, adjustable temperature control, and a lock to secure the contents.

### Features:

- Powder-Coated Red Finish with Full Steel Exterior
- Powerful Compressor Cooling
- Two Roller-Guided Metal Drawers for Tool and Hardware Storage
- Temperature Range 30-60°F
- Lockable Caster Wheels for Easy Mobility
- Interior LED Lighting with On/Off Switch
- Door Lock with Two Keys Included
- Freestanding Design (Clearance Required)

### MODEL:

### TBR-185SR

STORAGE VOLUME	1.8 CU. FT.
TEMPERATURE RANGE	30-60°F
NET WEIGHT	72.1 LBS
GROSS WEIGHT	89.3 LBS
UNIT DIMENSIONS (NOT INCLUDE THE FEET)	17"W 32" H X 21"D
PACKAGING DIMENSIONS	21" W X 34" H X 24" D
REFRIGERANT	R600A
ESTIMATED YEARLY ELECTRICITY USE	211 KWH
NOISE LEVEL	39 dB
UPC	850956003972

\*PLEASE NOTE THAT ALL TECHNICAL DATA PROVIDED ARE APPROXIMATE VALUES AND ESTIMATIONS. ACTUAL PERFORMANCE MAY VARY BASED ON ENVIRONMENTAL FACTORS AND SPECIFIC INSTALLATION CONDITIONS.

## INSTALLATION



### **WARNING: Excessive Weight Hazard**

Two or more people should move and install tool box refrigerator. Failure to do so can result in back or other injury.

### REMOVE PACKAGING MATERIALS

IMPORTANT: Do not remove any permanent instruction labels or the data label on your tool box refrigerator

### REMOVE TAPE AND GLUE FROM YOUR TOOL BOX REFRIGERATOR BEFORE USING

- To remove any remaining tape or glue, rub the area briskly with your thumb. Tape or glue residue can also be easily removed by rubbing a small amount of liquid dish soap over the adhesive with your fingers. Wipe with warm water and dry.
- Do not use sharp instruments, rubbing alcohol, flammable fluids, or abrasive cleaners to remove tape or glue inside the refrigerator compartment. These products can damage the inside surface.

### CLEANING BEFORE USE

- After you remove all of the packaging materials, clean the inside of your tool box refrigerator before using it.

### INSTALLATION REQUIREMENTS

Your tool box refrigerator should be conveniently located for day-to-day use in a dry, well-ventilated room. Do not install the tool box refrigerator where the temperature will go below 50°F or above 90°F, because it will not maintain proper temperatures. Be sure to install your tool box refrigerator on a floor strong enough to support it when it is fully loaded.

### FREESTANDING INSTALLATION

A freestanding installation will allow you to install the tool box refrigerator in any place you desire provided that the required clearance space around the appliance is respected. In every setting, there must be adequate ventilation and access for service. Never install or operate the unit in an enclosed area, such as a closed cabinet.

### CASTER WHEELS INSTALLATION

The refrigerator comes with four caster wheels, two of which are equipped with brakes (see Pg. 4). These wheels allow easier repositioning of the unit. Two or more people are required for installation.

1. Place a protective sheet or padding on the floor and carefully lay the unit on its back, ensuring it is stable and protected from scratches.
2. Remove the pre-installed feet and install the caster wheels into the same threaded holes, tightening securely with a wrench. Always install the two locking caster wheels on the front of the unit.
3. Install the remaining caster wheels, then carefully return the unit to an upright position, move it to the desired location, and engage the front caster brakes to lock it in place.

## INSTALLATION

---

- Before connecting the tool box refrigerator to the power source, let it stand upright for approximately 4 hours. This will reduce the possibility of a malfunction in the cooling system from handling during transportation.
- The normal operation of the tool box refrigerator depends on heat radiation from the condenser. Allow at least 6 inches of space between the back and sides of the appliance, which allows the proper air circulation to cool the compressor and condenser. The installation should allow the tool box refrigerator to be pulled forward for servicing if necessary.
- This unit **MUST** be installed in an area protected from the elements, e.g., wind, rain, water spray or drips. Do **NOT** use in an outdoor setting.
- The tool box refrigerator should not be located next to ovens, grills or other high heat resources.
- Too much humidity in the air will cause frost to form quickly on the evaporator, requiring more frequent defrosting of the tool box refrigerator.
- Avoid locating the appliance in area that may be exposed to excessive moisture.
- The tool box refrigerator must be installed with all electrical requirements followed.
- The unit should be located on a hard and level surface that can support the unit when it is full. It is important for the tool box refrigerator to be level in order to work properly.
- A standard electrical supply (115 VAC only, 60 Hz, 10A), properly grounded in accordance with National Electrical Code and local codes and ordinances is required.
- **IMPORTANT:** Do not kink or pinch the power supply cord between the tool box refrigerator and wall or compartment.

### MOVEMENT OF YOUR APPLIANCE

- Position the tool box refrigerator in a dry and well-ventilated place. Keep the tool box refrigerator away from direct sunlight, heaters, and corrosive gases or chemicals.
- Clean the interior surface with lukewarm water using a soft cloth.
- The tool box refrigerator can be simply moved from one room to another by using the pre-installed wheel rollers.
- If the appliance is needed to be lifted, two or more people should move tool box refrigerator. Failure to do so can result in back or other injury.
- We do not recommend installing the appliance on carpet.

## OPERATION AND CONTROLS

---

### TEMPERATURE CONTROL BOX

To obtain the best possible results for your tool box refrigerator, it is important that you operate it properly. Your tool box refrigerator uses a mechanical thermostat control knob which can be located at the back side of the refrigerator.

The temperature control knob is marked with the settings OFF, COLD, and COLDEST, in order of increasing coldness when turned. When set to the OFF position, the knob will click, and the freezer will stop running.

#### NOTE:

- Give your refrigerator time to cool down completely. It is best to wait for 24 hours before adding items.
- This refrigerator is not designed for use as a freezer. The temperature range for this tool box refrigerator is optimized for beverage storage. Perishable items may require a different storage environment.

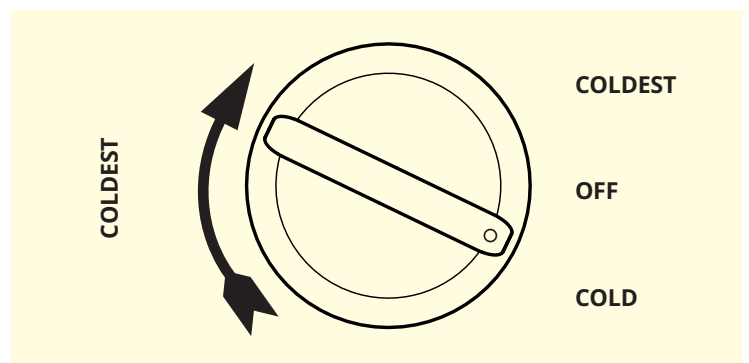

### INTERIOR LIGHT

To turn on/off the interior light, flip the switch next to the thermostat control knob. Please note that the interior light can only be controlled by this switch but not the opening and closing of the door.

### LOCK

This tool box refrigerator is equipped with a lock to keep your beverages safe and secure. Please note that only the large roller tool drawer and refrigerator cabinet will be secured when the lock is used.

### FRESH FOOD STORAGE

- Wrap or store food in the refrigerator in airtight and moisture – proof material. This prevents food odor and taste transfer throughout refrigerator.
- Fruit – wash, dry and store in refrigerator in plastic bags or crisper.
- Leafy vegetables- remove wrapping and trim or tear off bruised and discolored areas then wash in cold water and drain. Place in plastic bag or plastic container and store in crisper.
- Fish – use fresh fish the same day as purchased.
- Meat – store most meat in original wrapping as long as it is airtight and moisture – proof. Re-wrap if necessary.
- Leftovers – cover leftovers with plastic wrap or aluminum foil. Plastic containers with tight-seal lid can also be used.

### NOTE:

- For best performance, leave enough space in the refrigerator compartment for air to circulate around the packages. Also let enough room at the front so the door can close tightly.

### DEFROSTING

Under most ambient conditions, the appliance does not need to be defrosted. In cold ambient temperatures and/or high humidity, some frost may build up. To defrost the appliance, set the thermostat dial to “OFF”, remove frozen or perishable items and defrosting should occur in a few hours. After defrosting, return the thermostat dial to the desired position. For faster defrosting, remove all items from the appliance, unplug the appliance and leave the door open. Never use a knife or other metal instrument to scrape ice/frost from the evaporator.

### NORMAL SOUNDS

The unit is cooled by a compressor. The compressor pumps coolant through the cooling system, producing operating noise. Even when the compressor cuts out, noises caused by changes in temperature and pressure are unavoidable. Operating noise will be most audible immediately after the compressor comes on. It becomes quieter as the operating period continues.

The following noises are normal and occur from time to time:

- Gurgling sound, caused by the refrigerant flowing through the appliance’s coils
- Humming noise made by the compressor. This noise can get louder for brief periods when the motor is switching on.
- Cracking/popping sounds, resulting from the materials contraction and expansion due to temperature variations.
- Fan operating sound, to circulate the air within the refrigerator compartment.
- Unusual noise is normally the result of improper installation.
- In open-plan kitchens or when installed near partition walls, the sound of normal operation may be more noticeable.

## CLEANING AND MAINTENANCE

---

### OUTSIDE/EXTERIOR

- Wipe with a clean cloth lightly dampened with appliance polish wax or mild liquid dishwashing detergent. Dry and polish with a clean, soft cloth.
- Do not wipe the tool box refrigerator with a soiled dishwashing cloth or wet towel. Do not use scouring pads, powdered cleaners, bleach, or cleaners containing bleach.

### INTERIOR COMPARTMENT

- Turn off the power, unplug the appliance, and remove all items including shelves.
- Use warm water and baking soda solution—about a tablespoon of baking soda to a quart of water. Rinse thoroughly with water and wipe dry.
- Do not use cleaning powders or other abrasive cleaners.
- An open box of baking soda in the tool box refrigerator will absorb stale tool box refrigerator odors. Change the box every three months.

### CHANGING THE LIGHT BULBS

To change the light bulb, make sure to unplug tool box refrigerator or disconnect unit from power supply before removing the bulb. Replace the bulb with an 8-watt LED bulb. Please note that not all bulbs will fit your tool box refrigerator. Be sure to replace the bulb with one of the same size and shape. Plug in the tool box refrigerator or reconnect tool box refrigerator to power supply after bulb replacement.

### PREPARING FOR STORAGE

If the tool box refrigerator will not be used for a long time, or is to be moved to another place, it will be necessary to defrost the unit and dry the interior.

- Disconnect the tool box refrigerator from the power supply by removing the power plug from the wall socket. **WARNING:** Do not touch the power plug when your hands are wet. Never unplug the unit by pulling the cord.
- Leave the door open to allow air circulation and mold prevention, mildew and unpleasant smells.

**CAUTION:** Store the unit out of the reach of children. If you have children, you may want to take additional precautions such as locking the tool box refrigerator door.

### VACATION TIME

- Short vacations: Leave the appliance operating during vacations of less than two days.
- Long vacations: If the appliance will not be used for an extended period, remove all items and turn off the appliance. Clean and dry the interior thoroughly.

### MOVING YOUR APPLIANCE

- Remove all items inside the appliance.
- Securely tape down (we recommend using painter's tape) all shelves, drawers, and main door.
- Make sure the caster wheel brakes are released.
- Tape (we recommend using painter's tape) the door shut.
- Be sure the appliance stays secure in the upright position during transportation and protect the exterior of appliance with a blanket, or similar item..

### ENERGY SAVING TIPS

- The appliance should be located in the coolest area of the room, away from heat-producing appliances or heating ducts, and out of any direct sunlight.
- Ensure that the appliance is adequately ventilated. Never obstruct the air vents.
- Close the door tightly and do not open the appliance too frequently or for a long period of time.
- Store the content in an organized way.
- Do not over-fill the appliance to allow air to circulate.



## Troubleshooting

Many common tool box refrigerator problems are easily resolved. Try the troubleshooting suggestions below

Problem	Possible Causes	Solutions
The machine won't operate	<ul style="list-style-type: none"> <li>The tool box refrigerator is unplugged</li> <li>The voltage is not in the correct range</li> <li>Too many appliances running from the same power circuit</li> </ul>	<ul style="list-style-type: none"> <li>Push the plug completely into the power source</li> <li>Make sure that the tool box refrigerator runs on a dedicated power source that can support the maximum power consumption of the tool box refrigerator</li> <li>Run the tool box refrigerator on a dedicated power source</li> </ul>
Noise during operation	<ul style="list-style-type: none"> <li>Unit is not on a leveled surface</li> <li>Certain sounds are normal</li> </ul>	<ul style="list-style-type: none"> <li>Make sure unit is placed in a leveled surface</li> <li>See "Normal Sounds"</li> </ul>
The compressor runs for 1 to 5 minutes and stops	<ul style="list-style-type: none"> <li>The voltage is not in the correct range</li> </ul>	<ul style="list-style-type: none"> <li>Unplug and restart when the power is normal</li> </ul>
The compressor runs but the inner liner does not get very cold	<ul style="list-style-type: none"> <li>The ambient temperature is too high</li> <li>The system is blocked</li> </ul>	<ul style="list-style-type: none"> <li>If temperature is higher than 90°F, the unit need longer to cool to the set temperature</li> <li>Contact Whynter Customer Support</li> </ul>
The tool box refrigerator does not cool sufficiently	<ul style="list-style-type: none"> <li>Tool box refrigerator door being opened frequently</li> <li>Tool box refrigerator door left open for a while</li> <li>Not enough adequate clearance</li> <li>Tool box refrigerator is overfilled</li> <li>Ambient temperature is too high</li> </ul>	<ul style="list-style-type: none"> <li>Refrain from opening the tool box refrigerator door recurrently</li> <li>Make sure to close tool box refrigerator door Follow recommended clearance measurements</li> <li>If temperature is higher than 90°F, the unit need longer to cool to the set temperature</li> </ul>
The compressor does not run	<ul style="list-style-type: none"> <li>The controller is faulty (the power indicator is not on)</li> <li>The thermostat is set too high and the ambient temperature is</li> </ul>	<ul style="list-style-type: none"> <li>Contact Whynter Customer Support via email at <a href="mailto:support@whynter.com">support@whynter.com</a></li> <li>Set the tool box refrigerator to a lower temperature</li> </ul>
Interior light does not work	<ul style="list-style-type: none"> <li>No power at outlet</li> <li>Tool box refrigerator is unplugged</li> <li>Light bulb burned out</li> </ul>	<ul style="list-style-type: none"> <li>Replace fuse or reset the breaker</li> <li>Push the plug completely into the outlet</li> <li>Replace light bulb</li> </ul>
Door does not fully close	<ul style="list-style-type: none"> <li>Unit is not on a leveled surface</li> <li>Stored items holding door open</li> </ul>	<ul style="list-style-type: none"> <li>Make sure unit is placed in a leveled surface</li> <li>Move stored item to a different location</li> </ul>
Food is defrosting	<ul style="list-style-type: none"> <li>The tool box refrigerator is unplugged</li> <li>Fuse blown</li> <li>Tool box refrigerator door being opened frequently</li> <li>Tool box refrigerator door left open for a while</li> </ul>	<ul style="list-style-type: none"> <li>Push the plug completely into the power source</li> <li>Replace fuse or reset the breaker</li> <li>Check to see if an object is holding the door open</li> </ul>
Excessive frost buildup	<ul style="list-style-type: none"> <li>Door left open too frequent or too long door openings</li> <li>High humidity</li> <li>Door not closing properly</li> </ul>	<ul style="list-style-type: none"> <li>Check to see if an object is holding the door open</li> <li>Open the door less often</li> <li>Check door gasket</li> </ul>
Tool box refrigerator external surface is warm	<ul style="list-style-type: none"> <li>The external tool box refrigerator walls can be as much as 30° F warmer than room temperature</li> <li>Insufficient clearance around the unit</li> </ul>	<ul style="list-style-type: none"> <li>This is normal while the compressor works to transfer heat from inside of the tool box refrigerator compartment</li> <li>Ensure there is at least 6" of clearance around the unit</li> </ul>
Moisture forms on the walls of the tool box refrigerator	<ul style="list-style-type: none"> <li>Weather is hot and humid, which increases internal rate of frost buildup</li> <li>Door may not be closed properly</li> <li>Door is kept open too long, or is opened too frequently</li> </ul>	<ul style="list-style-type: none"> <li>This is normal</li> <li>Check door installation</li> <li>Open the door less often</li> </ul>
Odors in tool box refrigerator	<ul style="list-style-type: none"> <li>Interior needs to be cleaned</li> <li>Food with strong odors are in the tool box refrigerator</li> </ul>	<ul style="list-style-type: none"> <li>Clean interior with sponge, warm water, and baking soda</li> </ul>



### Live Support

Still having issues? Get real-time help through our live chat.





## ONE YEAR LIMITED WARRANTY

Warranty begins from the original date of purchase

This WHYNTER product is warranted, to the original owner within the 48 continental states, for one year from the date of purchase against defects in material and workmanship under normal use and service. When making a warranty claim, please have the original bill or invoice of purchase with purchase date available. Should your WHYNTER product prove defective within one year from the date of purchase, return the defective part or unit, freight prepaid (within two months of purchase; after two months to one year, customer will be responsible for freight cost to Whynter's service department), along with an explanation of the claim to Whynter LLC. A return authorization number issued by Whynter is required for all warranty claims and returns. Please package the WHYNTER product carefully in its original packaging material to avoid damage in transit. The original box and packaging material should be retained, as Whynter is not responsible for the cost of replacement packaging. Under this warranty, Whynter will repair or replace any parts found defective at our discretion. This warranty is not transferable. After the expiration of the warranty, the cost of labor and parts will be the responsibility of the original owner of the unit.

### THIS WARRANTY DOES NOT COVER:

- Acts of God, such as fire, flood, hurricanes, earthquakes and tornadoes.
- Improper power supply such as power surge, low voltage, defective household wiring or inadequate fuses.
- Use in commercial or industrial applications.
- Damage, accidental or otherwise, to the product while in the possession of a consumer not caused by a defect in material or workmanship.
- Damage caused by consumer misuse, tampering, lack of maintenance or failure to follow the care and special handling provisions in the instructions.
- Damage to the finish of the case, or other appearance parts caused by wear.
- Damage caused by repairs or alterations to the product by anyone other than authorized by the manufacturer.
- Removal, Replacement Packaging, Freight and Insurance cost for the warranty service.
- Products sold AS IS or from an unauthorized reseller.
- Products that have had their serial numbers removed or defaced.

### DISCLAIMER OF IMPLIED WARRANTIES; LIMITATION OF REMEDIES

*CUSTOMER'S SOLE AND EXCLUSIVE REMEDY UNDER THIS LIMITED WARRANTY SHALL BE PRODUCT REPAIR OR REPLACEMENT AS PROVIDED HEREIN. CLAIMS BASED ON IMPLIED WARRANTIES, INCLUDING WARRANTIES OF MERCHANTABILITY OR FITNESS FOR A PARTICULAR PURPOSE, ARE LIMITED TO ONE YEAR OR THE SHORTEST PERIOD ALLOWED BY LAW, BUT NOT LESS THAN ONE YEAR. WHYNTER SHALL NOT BE LIABLE FOR CONSEQUENTIAL OR INCIDENTAL DAMAGES SUCH AS PROPERTY DAMAGE AND INCIDENTAL EXPENSES RESULTING FROM ANY BREACH OF THIS WRITTEN LIMITED WARRANTY OR ANY IMPLIED WARRANTY. SOME STATES AND PROVINCES DO NOT ALLOW THE EXCLUSION OR LIMITATION OF INCIDENTAL OR CONSEQUENTIAL DAMAGES, OR LIMITATIONS ON THE DURATION OF IMPLIED WARRANTIES, SO THESE LIMITATIONS OR EXCLUSIONS MAY NOT APPLY TO YOU. THIS WRITTEN WARRANTY GIVES YOU SPECIFIC LEGAL RIGHTS. YOU MAY ALSO HAVE OTHER RIGHTS THAT VARY FROM STATE TO STATE. PRODUCT CONTENTS AND SPECIFICATIONS MAY CHANGE WITHOUT NOTICE.*



**Need Help Fast?  
Chat with Us!**  
Get instant answers 24/7



**Proof of Purchase**  
Please Retain Original  
Proof of Purchase



**Need Help Fast?**  
**Chat with Us!**  
Get instant answers 24/7



**JOIN THE  
CONVERSATION**



**E: [support@whynter.com](mailto:support@whynter.com) | T: 866-WHYNTER | [www.whynter.com](http://www.whynter.com) | ©2026 Whynter LLC**

Disclaimer: All information and technical data provided in this manual are approximate values and estimations. Whynter reserves the right to modify product specifications or documentation without prior notice to improve performance and safety.