



Whynter BSR-080SB 15 inch Built-In 80 Can Stainless Steel Beverage Refrigerator with Reversible Door, Digital Control, Lock and Carbon Filter

BSR-080SB

INSTRUCTION MANUAL



Congratulations on your new Whynter product. To ensure proper operation, please read this Instruction Manual carefully before using this product. Keep this manual in a safe place for future reference.

TABLE OF CONTENTS

SAFETY PRECAUTIONS01
PRODUCT FEATURES03
INSTALLATION INSTRUCTIONS05
OPERATING YOUR BEVERAGE COOLER08
TROUBLESHOOTING GUIDE11
WARRANTY14



Whynter - Redefining Luxury Since 2006

Born from Innovation, Built for Excellence

Since 2006, Whynter, based in California, USA, has been dedicated to redefining modern living through high-end appliances that combine craftsmanship, quality, and cutting-edge technology.

Crafted to exceed and designed to inspire, each product is built with premium materials and precision engineering to deliver superior performance, energy efficiency, and sleek design.

Whynter is more than an appliance. It is a statement of distinction. A symbol of modern sophistication, it elevates everyday living into a refined experience.

APPLIANCE SAFETY

Your safety and the safety of others are very important to us.

To reduce the risk of fire, electrical shock, or injury when using your appliance, follow these basic precautions:



This is the Safety Alert Symbol. This symbol alerts you to potential hazards that may result in serious injury. All safety messages will follow the Safety Alert Symbol and either the words "DANGER" or "WARNING".



Danger means that failure to heed this safety statement may result in severe injury or death.



Warning means that failure to heed this safety statement may result in extensive product damage, serious injury, or death.



Caution means that failure to heed this safety statement may result in minor or moderate injury, or property or equipment damage.

All safety messages will alert you to know what the potential hazard is, tell you how to reduce the chance of injury, and let you know what can happen if the instructions are not followed.

IMPORTANT SAFEGUIDES



Before the appliance is used, it must be properly positioned and installed as described in this manual, please read the manual carefully. To reduce the risk of fire, electrical shock or injury when using the appliance, follow basic precautions, including the following:



- Plug into a grounded 3-prong outlet, do not remove grounding prong, do not use an adapter, and do not use an extension cord.
- Do not use if the power supply cord is damaged. If damaged, it must be replaced by a qualified electrician.
- It is recommended that a separate circuit, serving only your appliance be provided. Use receptacles that cannot be turned off by a switch or pull chain.
- Never clean appliance parts with flammable fluids or harsh chemicals. These fumes can create a fire hazard or explosion.

- Do not store or use gasoline or other flammable vapors and liquids in the vicinity of the appliance or any other appliance.
- Before proceeding with cleaning and maintenance operations, make sure to unplug the appliance.
- Do not connect or disconnect the electric plug with wet hands.
- Do not attempt to repair or replace any part of your appliance unless it is specifically recommended in this manual. All other servicing should be referred to a qualified technician.
- This appliance is CFC- and HFC- free and contains small quantities of Isobutane (R600a) which is environmentally friendly, but flammable. It does not damage the ozone layer, nor does it increase the greenhouse effect. Care must be taken during transportation and setting up of the appliance that no parts of the cooling system are damaged. Leaking coolant can ignite and may damage the eyes.

In the event of leakage:

- Avoid open flames and anything which creates a spark
- Disconnect from the mains
- Air the room in which the appliance is located for several minutes and contact the Service Department for advice



FOLLOW WARNING CALL OUTS BELOW ONLY WHEN APPLICABLE TO YOUR MODEL

- Use two or more people to move and install the appliance. Failure to do so can result in injury.
- To ensure proper ventilation for your appliance, the front of the appliance must be completely unobstructed. Choose a well-ventilated area with temperatures above 60°F (16°C) and below 90°F (32°C). This appliance must be installed in an area protected from the element, such as wind, rain, water spray or drips.
- The appliance should not be located next to ovens, grills or other sources of high heat.
- The appliance must be installed with all electrical connections in accordance with state and local codes.
- The fuse (or circuit breaker) size should be 15 amperes.
- It is important for the appliance to be leveled in order to work properly. For a stable installation, make sure the appliance is placed on a flat, level and solid surface.
- Ensure that the surface on which the appliance is placed is strong enough to hold the appliance and the items stored inside.
- This appliance is not intended for use by young children or physically-challenged persons without supervision/ assistance. Young children must be supervised to ensure safety around this or any appliance.
- Do not use solvent-based cleaning agents or abrasives on the interior. These cleaners may damage or discolor the interior.
- Keep fingers out of the "pinch point" areas. Clearance between the doors and between the doors and cabinet are necessarily small. Be careful closing doors when children are in the area.
- This refrigerator is designed to store beverage cans and wine bottles. If food is stored inside, ensure that there is sufficient airflow between items. Please note that the temperature range for this refrigerator is optimized for wine and beverage storage. Perishable food items may require a different storage environment.
- Do not place hot food or beverages into the appliance.
- Close the refrigerator doors immediately after putting in any items to keep the internal temperature relatively constant.
- Avoid placing any objects on top of the appliance.
- This is an electrical appliance, to avoid injury from electrical shock do not operate the unit with wet hands, while standing on a wet surface or while standing in water. Do not use outdoors or in wet conditions.
- When positioning or moving the appliance, ensure that it is not turned up side down or unlevelled greater than 45°
- Never pull the power cord to disconnect it from the outlet. Grasp the plug and pull it from the outlet.
- Never lift, carry or drag the appliance by the power cord.
- This appliance is designed for household, non-commercial use only. Any other use will void the warranty.
- Do not plug into the power outlet before set up is completed.
- Do not move this appliance without emptying it and securing the door in a closed position.

PRODUCT PARTS



1.Light	6.Door Gasket	11.Keys
2.Shelves (3)	7.Door Lock Latch	12.Drip Tray
3.Door Handle	8.Bottom Grille	13.Power Cord
4.Control Panel	9.Cylinder Lock	14.Bottom Left Door Hinge
5.Door	10.Leveling Legs (4)	15.Upper Door Hinge
		16.Activated Carbon Filter (in cabinet)



PRODUCT FEATURES

The Whynter BSR-080SB beverage refrigerator is a sophisticated addition to any home and perfect for cooling and storing your favorite beers and canned beverages. With its reversible and elegant full glass door, this beverage refrigerator blends well and accents any decoration.

Its standard counter height makes it ideal for in-cabinet installation. The front-venting design allows you to install this beverage refrigerator under a kitchen counter or cabinet for a seamless appearance. Effortlessly control the three-color LED lights and temperature settings of your beverage refrigerator using the digital control panel. While the see-through tempered double pane glass door displays your beverage collection, this unit is equipped with three-color interior light that makes it easy to find exactly what you are looking for.

Features fan-forced circulation to maintain an evenly-cooled space ensuring consistent temperatures throughout the interior for more effective and efficient operation. The auto defrost feature also allows for maintenance-free continuous operation (We still recommend powering the unit off during extended periods of non-usage).

This beverage refrigerator has the capability of the door opening from either the left or right side, if you prefer a certain direction or would like the unit to follow the flow of your kitchen design. The cylinder door lock provides protection and additional security from unauthorized access to your beverage refrigerator.

Features

- Capacity: 80 standard 12 oz. cans
- Built-in/ Freestanding installation
- Stainless trimmed glass door with sleek black cabinet
- Touch screen control with temperature range from 34°F- 54°F/ 1°C- 12°C
- Environment friendly refrigerant
- Activated carbon filter eliminates odors
- Tempered double-pane gray-smoked glass for enhanced UV protection
- Reversible door orientation
- Three-color interior LED lighting with on/off switch
- Internal fan-forced circulation for even temperature distribution throughout the cabinet
- Cylinder lock and two keys
- Fahrenheit and Celsius degree temperature indicators

Technical Data:

Voltage:	115V/60Hz
Rated Current:	0.9A
Capacity:	80 standard 12 oz. cans
Temperature Range:	34°F- 54°F (1°C- 12°C)
Net Weight:	69.9 lbs
Gross Weight:	81.6 lbs
Unit Dimension:	14.8" W x 22.4" D x 33.9" H
Packaging Dimension:	18.5" W x 25.7" D x 37.8" H
Refrigerant:	R600a

Before Using the Appliance

- Remove the exterior and interior packing.
- Before connecting the appliance to the power source, let it stand upright for approximately 4 hours. This will reduce the possibility of a malfunction in the cooling system from handling during transportation.
- Clean the interior surface with lukewarm water using a soft cloth.
- Install the handle on the door.

Installation of the Appliance

- The appliance is designed for built-in, recessed or freestanding installation.
- **WARNING:** Do not store or install the appliance outdoors.
- **CAUTION:** This appliance is designed for storing and cooling beverages. Do not store perishable food, medicine or other medical products.
- Place your appliance on a hard and level floor that is strong enough to support it when it is fully loaded.
- We do not recommend installing the appliance on carpet.
- To level your appliance, adjust the leveling legs at the bottom of the appliance if needed.
- For freestanding installation, 5 inches (127mm) of space between the back and sides of the appliance are suggested, which allows the proper air circulation to cool the compressor and condenser. Even for built-in installation, it is a must to keep a ¼" (6.35mm) space on each side and at the top. And the air vent at the front of the appliance must never be covered or blocked in any way.
- **NOTE:** Do NOT install the appliance near an oven or other heating source. Direct sunlight may affect the acrylic coating and heat sources may increase electrical consumption. For best performance, do not install the appliance behind a cabinet door or block the base grille.
- Avoid locating the appliance in area that may be exposed to excessive moisture.
- Plug in the appliance into an exclusive, grounded wall power outlet. Do not under any circumstances cut or remove the third (ground) prong from the power cord. Any questions concerning power and/or grounding should be directed toward a qualified electrician or an authorized service center.

Built-in Cabinet Instructions

- Minimum Width: 15.05"
- Minimum Depth: 22.65"
- Minimum Height: 34.25"

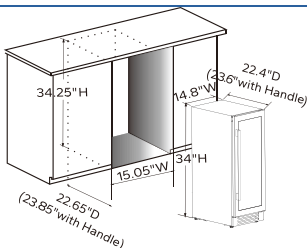

This appliance is designed for both built-in or freestanding installation. For built-in installation, ensure proper service access and ventilation, allow at least ¼" (6.35mm) space on each side and at the top.

Electrical Connection

WARNING

Improper use of the grounded plug can result in the risk of electrical shock. If the power cord is damaged, have it replaced by a qualified electrician or contact Whynter Service Department

This appliance requires a standard 115/120 Volt AC ~/60Hz electrical ground outlet with three-prong. Have the wall outlet and circuit checked by a qualified electrician to make sure the outlet is properly grounded. The cord should be secured behind the appliance and not left exposed or dangling to prevent accidental injury.

The appliance should always be plugged into its own individual electrical outlet which has a voltage rating that matches the rating label on the appliance. This provides the best performance and also prevent over loading house wiring circuits that could cause a fire hazard from over heated. Never unplug the appliance by pulling the power cord. Always grip the plug firmly and pull straight out from the receptacle. Repair or replace immediately all power cords that have become frayed or otherwise damaged. Do not use a cord that shows cracks or abrasion damage along its length or at either end. When moving the appliance, be careful not to damage the power cord.

Extension Cord

Because of potential safety hazards, it is strongly recommended that you do not use an extension cord with this appliance. However, if you must use an extension cord, it is absolutely necessary that it be a UL/ CUL-Listed, 3-wire grounding type extension cord having a grounding type of plug and outlet, and that the electrical rating of the cord is 115 volts and at least 10 amperes.

Installing the Handle

This stainless steel handle that is not required for operation. To install the handle please follow the below instructions:

1. Remove door gasket. The gasket can be easily displaced by hand, no tools are necessary.
2. Use a flat-head screwdriver to remove the two pre-installed decorative screw covers from the back of the door. Some models have no decorative covers.
3. Install the handle tightly as shown with the two screws, lock washers and flat washers provided. (DO NOT over tighten as this will cause damage to the handle and stainless steel door frame).
4. Replace the door gasket.

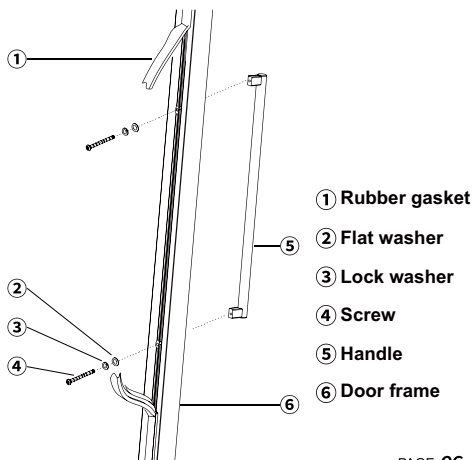

Revising the Door

This appliance has the capability of the door opening from either the left or right side. The appliance is delivered to you with the door opening from the left side. Should you desire to reverse the opening direction, please follow the following reversal instructions.

1. Please remove the bottom hinge holder ② by unscrewing the two lock screws. Be careful to hold the glass door firmly after removing the screws. **Please check Figure 1**
2. Gently pull down to remove the glass door from the right top hinge and place it on a padded surface to avoid the risk of damage. **Please check Figure 2**
3. Using a flat-head screwdriver, gently pry up the decorative hinge cover plate on the top left of the unit and the round black decorative cover caps on the upper left side corner of the inside cabinet frame. Use them to cover the screw holes on the right-hand side. **Please check Figure 2**
4. Move the top hinge from the right-hand side to and use the upper right hinge that is equipped along with the manual in the cabinet to install on the left side of cabinet by removing the screws ⑦. **Please check Figure 3/4**
5. Relocate the door to the left-hand side of cabinet by placing the door hinge holes into the hinge, then screw the bottom hinge assembly with the lower hinge fixer ④ onto the left designated position and tighten after the door is leveled. **Please check Figure 4**

Figure 1

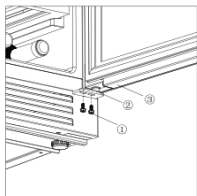

Figure 2

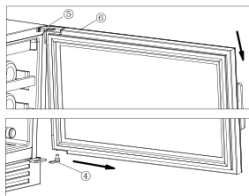

Figure 3

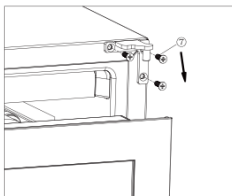



Figure 4





It is recommended you install the appliance in a place where the ambient temperature is between 72°-78°F / 23°C- 26°C, if the ambient temperature is above or below recommended temperatures, the performance of the beverage refrigerator may be affected. For example, placing your appliance in extreme cold or hot conditions may cause interior temperatures to fluctuate.

Control Panel



- **POWER** 

To turn the appliance on/off, press and hold the power key for 5 seconds.
- **UP** 

To increase (warm) the set temperature by 1°C or 1°F.
- **DOWN** 

To decrease (cool) the set temperature by 1°C or 1°F.
- **LIGHT** 

Switch between 3 different colors and off, the light color switch option is in white, blue, and amber color.
- When using the beverage refrigerator for the first time or restarting after being shut off for a long period of time there may be a few degree variance between the set temperature and the LED readout. This is normal due the length of activation time. The unit should return to normal after running for a few hours.

WARNING

This product is designed for storing and cooling beverage. It is not intended for storage of perishable foods.

Large Storage Capacity

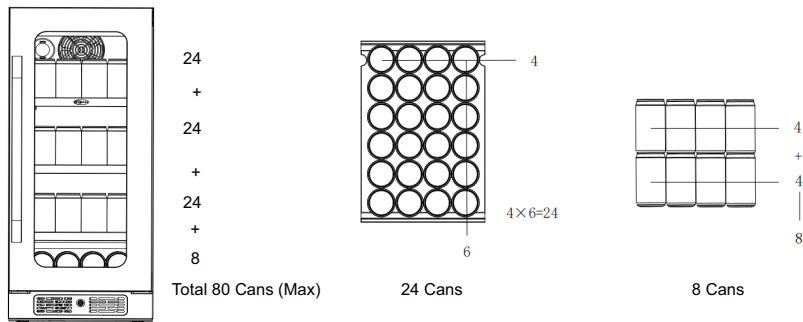

Beverage cans may differ in size and dimensions so the actual number of cans can be stored may vary. The 80-can capacity is the approximate maximum when storing traditional 12 oz. cans and includes bulk storage. You may load your beverage cans in single row or by stacking while taking note of the following: if you do not have enough cans to fill your beverage refrigerator, it is better to distribute the load throughout the beverage refrigerator so as to avoid "all on top" or "all below" type loads.

- You can remove or relocate adjustable shelves to accommodate larger type of cans. Keep small gaps between the walls and the bottles to allow air circulation.
- Do not over load your beverage refrigerator.
- Avoid obstructing the internal fans (located inside on the back panel of the beverage refrigerator).
- Do not try to slide the shelves outwards beyond the fixed position to prevent the bottles from falling.
- Do not pull out more than one loaded shelf at a time as this may cause the beverage refrigerator to tilt forward if not properly installed.

Shelves

- This appliance is equipped with 3 pcs of glass shelves and you can move the shelves out and in smoothly.
- To prevent damaging the door gasket, make sure to have the door all the way opened when pulling shelves out of the product. For easy access to the drinks, you must pull the shelves approximately 1/3 out of the cabinet.

Moving the Beverage Cooler

- Remove all items.
- Securely tape down (we recommend using painter's tape) all loose items (shelves) inside your appliance.
- Turn the adjustable leg up to the base to avoid damage.
- Tape (we recommend using painter's tape) the door shut.
- Be sure the appliance stays secure in the upright position during transportation and protect the exterior of appliance with a blanket, or similar item.

Cleaning Your Appliance

- Turn off the power, unplug the appliance, and remove all items including shelves.
- Wipe the interior with warm water and baking soda solution. The solution should be about 2 table-spoons of baking soda to one quart of water.
- Wipe the shelves with a mild detergent solution.
- Wipe the outside cabinet with warm water and mild liquid detergent.
- Do not use steel wool or steel brush on the stainless steel. These will erode the stainless steel and rusting may occur.

WARNING

Failure to unplug the appliance could result in electric shock or personal injury

Vacation Time

- Short vacations: Leave the appliance operating during vacations of less than two days.
- Long vacations: If the appliance will not be used for an extended period, remove all items and turn off the appliance. Clean and dry the interior thoroughly.

Premises Power Failure

- In the event of a power interruption, all previous temperature settings are automatically memorized. If power is interrupted (power surge, breaker switch, etc.) and then powered up again, the unit will operate with the last temperature set-point.
- Most power failures are corrected within a few hours and should not affect the temperature of your appliance if you minimize the number of times the door is opened. If the power is going to be off for a longer period of time, you need to take the proper steps by following Troubleshooting Guide to protect your contents.

Activated Carbon Filter System

The Whynter BSR-080SB is equipped with one activated carbon filter, which ensures optimum air quality within the beverage cabinet. This filter counters and prevents any contaminants and odors from the ambient air affecting the taste of the beverages stored. Replace the activated carbon filter once a year. If you are interested in purchasing an additional charcoal filter, please contact: support@whynter.com for retail sales information.

To change the filter,

- Turn the filter cover 90° clockwise or counterclockwise and then remove the filter.
- Insert the new filter in the vertical position.
- Turn the filter cover 90° clockwise or counterclockwise until it click into position.



Energy Saving Tips

- The appliance should be located in the coolest area of the room, away from heat producing appliances, and out of any direct sunlight.
- Ensure that the appliance is adequately ventilated. Never obstruct the air vents.
- Close the door tightly and do not open the appliance too frequently or for a long period of time.
- Store the content in an organized way.
- Do not over-fill the appliance to allow air to circulate.

You can solve many common wine/ beverage refrigerator problems easily, saving you the cost of a possible service call. Please try the suggestions below to see if you can solve the problem before emailing the service team.

PROBLEM	POSSIBLE CAUSE	SOLUTION
Product does not operate.	Not plugged in. The appliance is turned off. The circuit breaker tripped or a blown fuse.	Plug the unit. Turn on the unit. Check the breaker and/or fuses.
Product is not cold enough.	External environment may require a lower temperature setting. The door is opened too often. The door is not closed completely. The door gasket does not seal properly.	Check the temperature control setting. Close the door properly. Check the door gasket.
The compressor turns on and off frequently.	The room temperature is higher than normal. A large amount of contents has been added to the refrigerator. The door is opened too often. The door is not closed completely. The temperature control is not set correctly. The door gasket does not seal properly.	Close the door properly. Check the door gasket.
The fans turn on and off frequently.	The ambient room temperature is too low or high. A large amount of contents has been added to the appliance. The door is opened too often. The door is not closed completely. The door gasket does not seal properly.	Decrease or increase the ambient room temperature. To minimize internal temperature fluctuation, do not add large amount of contents at once. Close the door tightly and do not open the door too frequently or for a long period of time. Ensure the door gasket is not loose.
Fan is always running.	This is simply a function of the cooling system. The lower the setting, the more the fan will run. If the room is very warm, the refrigerator will run more. The unit has been designed to run continuously when operating at the lower temperatures.	If the fan keeps running at a relatively high set temperature. 1. Check the unit is cooling--Wait 15 minutes and check if the fan has stopped. 2. Check the unit is not cooling--Call service center.
The light does not work.	Not plugged in. The circuit breaker tripped or a blown fuse. The light button is "OFF",	Plug the unit. Check the breaker and/or fuses.

PROBLEM	POSSIBLE CAUSE	SOLUTION
Appliance shaking.	The beverage cooler is not properly leveled.	Check to ensure that the refrigerator is level.
	There is an object under the refrigerator.	Make sure the bottles don't touch each other. Remove the object.
The product seems to make too much noise.	The unit is not level.	Level the refrigerator. The rattling noise may come from the flow of the refrigerant, which is normal. As each cycle ends, you may hear gurgling sounds caused by the flow of refrigerant in your refrigerator. Contraction and expansion of the inside walls may cause popping and crackling noises.
	Frost appears in cabinet (on back).	Either too much humidity or too low of temperature inside cabinet. Unplug refrigerator and allow to manually defrost. Reconnect when ice has melted. If problem persists, contact for service instructions.
The door will not close properly.	The refrigerator is not level.	Level the refrigerator.
	The door was reversed and not properly installed.	Close the door properly.
	The gasket is dirty.	Clean the door gasket.
	The shelves are out of position.	Place the shelves properly.

If the above problems occur and cannot be solved by following the instructions, please contact us by email: support@whynter.com. Please describe your problems in detail in words, pictures or videos, and we will answer you as soon as we receive your feedback.

PROBLEM	POSSIBLE CAUSE	SOLUTION
Display shows: E1 E2 , E5, E6, E7, E8, E9 , EA, EU	Temperature sensor failure or	Please call the service center.
L0	Low temperature alarm	Please call the service center.
HI	High temperature alarm	Please confirm whether the internal and external fans are operating and whether the compressor is started? Both of the above are fine, but the temperature sensing probe is faulty; If the internal fan does not turn, it is a fan malfunction. All of the above questions, please contact the customer service center.
Et	Temperature difference alarm	<p>Please turn off the product and unplug the power supply, open the door for ventilation for 24-36 hours, and then the error can be cleared.</p> <p>If the problem is not solved after ventilation, you could also carefully remove the back plate of the fan inside the box to determine if there is ice formation. After the ice melts, restart the machine to set the temperature. It is recommended not to set the minimum temperature at this time</p>
E0	The door is not closed properly	Check if the door is not tightly closed. If it is not properly closed, close the door again. If unable to resolve the issue please contact after-sales service.

ONE YEAR LIMITED WARRANTY

This WHYNTER product is warranted to the original owner, purchased from an authorized Whynter dealer within the 48 U.S. continental states, for one year from the original purchase date against defects in material and workmanship under normal residential usage. Should your WHYNTER product prove defective within one year from the date of purchase, contact Whynter's Customer Support Team with the serial number and proof of purchase to make a warranty claim. A Return Authorization Number must be issued before returning any parts or products. Parts or products received without a Whynter issued Return Authorization Number will be refused. Under this warranty, Whynter will repair or replace any parts found defective with new or remanufactured parts or exchange the defective product with a new, refurbished, or remanufactured product at our discretion. All defective products and parts covered by this warranty will be repaired or replaced on a mail-in basis to Whynter's Service Center. This warranty is not transferable. After the expiration of the warranty, the cost of labor and parts will be the responsibility of the original owner.

Return freight is prepaid by Whynter within two months of purchase. After two months to one year, the customer will be responsible for the return freight cost to Whynter's Service Center. Please package the product carefully in its original packaging to avoid damage in transit. Whynter is not responsible for damage resulting from shipper mishandling or improper packaging. Please retain the original box and packaging materials.

THIS WARRANTY DOES NOT COVER:

- Acts of God, such as fire, flood, hurricanes, earthquakes and tornadoes.
- Improper power supply such as power surge, low voltage, defective household wiring or inadequate fuses.
- Use in commercial or industrial applications.
- Damage, accidental or otherwise, to the WHYNTER Beverage Wine Refrigerator while in the possession of a consumer not caused by a defect in material or workmanship
- Damage caused by consumer misuse, tampering, or failure to follow the care and special handling provisions in the instructions.
- Damage to the finish of the case, or other appearance parts caused by wear.
- Damage caused by repairs or alterations to the product by anyone other than authorized by the manufacturer.
- Removal, Replacement Packaging, Freight and Insurance cost for the warranty service.

DISCLAIMER OF IMPLIED WARRANTIES; LIMITATION OF REMEDIES

CUSTOMER'S SOLE AND EXCLUSIVE REMEDY UNDER THIS LIMITED WARRANTY SHALL BE PRODUCT REPAIR OR REPLACEMENT AS PROVIDED HEREIN. CLAIMS BASED ON IMPLIED WARRANTIES, INCLUDING WARRANTIES OF MERCHANTABILITY OR FITNESS FOR A PARTICULAR PURPOSE, ARE LIMITED TO ONE YEAR OR THE SHORTEST PERIOD ALLOWED BY LAW, BUT NOT LESS THAN ONE YEAR. WHYNTER SHALL NOT BE LIABLE FOR CONSEQUENTIAL OR INCIDENTAL DAMAGES SUCH AS PROPERTY DAMAGE AND INCIDENTAL EXPENSES RESULTING FROM ANY BREACH OF THIS WRITTEN LIMITED WARRANTY OR ANY IMPLIED WARRANTY. SOME STATES AND PROVINCES DO NOT ALLOW THE EXCLUSION OR LIMITATION OF INCIDENTAL OR CONSEQUENTIAL DAMAGES, OR LIMITATIONS ON THE DURATION OF IMPLIED WARRANTIES, SO THESE LIMITATIONS OR EXCLUSIONS MAY NOT APPLY TO YOU. THIS WRITTEN WARRANTY GIVES YOU SPECIFIC LEGAL RIGHTS. YOU MAY ALSO HAVE OTHER RIGHTS THAT VARY FROM STATE TO STATE.

The warranty, product contents and specifications are subject to change at any time without notice; please refer to www.whynter.com for the most current information.

To register your warranty, please visit www.whynter.com and fill out the online warranty Registration form. Please be sure to include a Copy of your purchase invoice.

To obtain service or information, contact Whynter LLC via email at support@whynter.com or call 866-WHYNTER (866-949-6837) .

Copyright 2025 Whynter LLC

www.whynter.com

